

MITREPLAN PROJECT PLANNER

Build a storage chest



- **An easy-to-follow guide to achieving a perfect result.**
- **Outlines all the tools you will need for the job.**
- **Includes a materials checklist.**

PLEASE NOTE:

Before starting this project or buying any materials, it is worth your time to read all steps thoroughly first to be sure you understand what is required.

Mitre 10 is proudly Australian owned.

#25

mitre10.com.au

MIGHTY HELPFUL™ MITRE 10

MIGHTY TOOLS FOR YOUR MITREPLAN

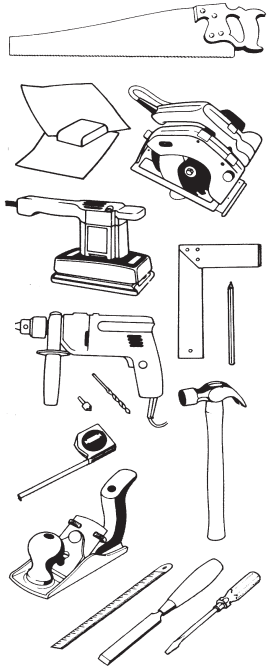

Power saw or hand saw

Power drill and bits

Power sander

Sandpaper

Carpenter's square

Plane

Hammer

Nail punch

Measuring tape

Ruler or straightedge

Pencil

Screwdriver

(if required for hinges)

✓ MIGHTY HELPFUL CHECKLIST

Timber

The sides, bottom and lid are made from 12mm thick tongue and groove 'V' jointed profile pine lining boards. But you can also use other types of timber and dimensions depending on your preference. Long lengths can be supplied sufficient for you to cut the required pieces. When ordering, be sure to say that you need lengths from which at least four 890mm pieces can be cut.

ORDER

Pine Lining Boards		
22 pieces 560mm long		5/2.4 1/1.2m
4 pieces 893mm long		1/3.6m
7 pieces 545mm long		1/1.8 1/2.4m
42 x 19mm Pine Battens		
A – 4 pieces 893mm long		1/3.6m
B – 2 pieces 850mm long		1/1.8m
C – 4 pieces 483mm long		1/2.1m
D – 3 pieces 520mm long		1/1.8m
Hardware		
Piano hinge 1 x 900mm		
PVA glue		
32 Screws – 4 gauge x 10mm (for fixing hinges)		
Packet 25mm bullet head nails		
Packet 30mm bullet head nails		
Lift-up lid stay		
Pine coloured wood filler		
Other materials		

Verbal quotes are indicative only. Written quotes on materials are available upon request from your Mitre 10 store.

It's easy to build a chest – with help from Mitre 10.

Most people never seem to have enough storage space. So here's a way to create some more and add an attractive piece of furniture to your home.

In the bedroom it's ideal for storing linen, sweaters, blankets and bedspreads. Use it as a toy box to help keep a child's bedroom neat and tidy. Or use it in the family room to store hobby equipment, sports gear, records and tapes. It's a natural in the sewing room, too, for material and patterns. Or set it near the main entry for gloves, boots or off-season clothes.

The chest is 917mm long x 545mm wide x 572mm high, but if you want even more room, the proportions can easily be enlarged. And it's easy to build – just follow these simple instructions and your storage problems will be solved in no time by Mitre 10.

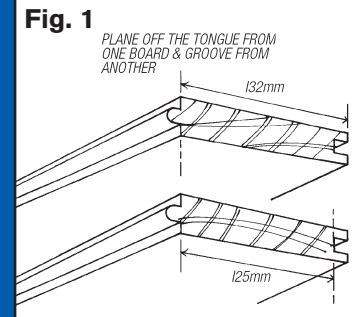

Step 1: Make the sides

Start by forming the two long sides. For each side, cut 7 lining boards 560mm long, and 2 battens 893mm long.

First, plane the tongue off two of the lining boards, and the groove off the two other lining boards (Fig. 1). These boards are for the start and ends of the long sides.

Now check with your carpenter's square that the edges are square down the length of each board, and that all the boards are the same length. Find a flat, clean surface to work on. Then select which side of the boards you want to be the visible external surface. Lay out two 893mm battens ('A') 548mm from outer edge to outer edge. As you work remember that all boards should be glued to the battens as well as nailed.

Place one of the boards (which you removed the groove from) on the battens and position it so the top is flush to the top batten and the bottom batten is 12mm up from the bottom of the board. Also the board needs to hang over the end of both battens by 12mm, (Fig. 3) and down below the bottom batten by 12mm. With your carpenter's square check that the battens and boards are square to each other and that the battens are parallel. Glue and nail the lining board to the battens with two 25mm nails top and bottom. All nails except the starting nail on the first board and the finishing nail on the last board can be 'secretly' nailed by nailing at an angle through the tongue (Fig 2).

With a fine punch, drive the head of the nail below the pine surface. To guard against splitting it is best to pre-drill the nail holes with a drill bit about three quarters the diameter of the nail.

Now glue, fit and nail each board ensuring that the interlocking tongue and groove fit neatly with no gaps between the boards. Keep the top of each board flush to the top batten and maintain the 12mm overhang on the bottom batten (Fig. 3).

The last board to be fitted will be the board that had the tongue removed and this board should also hang over the end of the battens by 12mm.

Punch the end visible surface nail just below the surface for later filling.

When you've completed one long side, repeat the procedure for the other side.

Step 2: Make the ends

The ends are formed in much the same way as the long sides were. Two battens 483mm long ('C') are placed 548mm apart measured from outer edge to outer edge. Four lining boards 560mm long, the first board with the groove removed and the last with the tongue removed, are fitted tightly together onto the battens with glue and nails. Again ensure that boards and battens are square to each other and that the top batten is flush to the top of the boards and the bottom batten is 12mm up from the bottom.

The battens for the ends are positioned 19mm from the end edge of the first and last lining boards (Fig. 4).

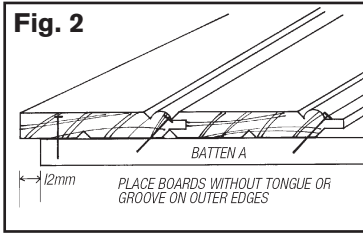

Step 3: Form the chest

The chest is now formed by fixing the ends between the two sides with glue and nails.

But before you do it, check that all boards and battens for the sides and ends are tightly fixed together. Also test that all edges fit evenly and neatly together.

Stand one long side the correct way up on your work surface, and place an assembled end into the 12mm space between the end of the side and the top and bottom battens. The top and bottom battens of the end and side panels should line up on the inside, with the outer face flush at the corner (Fig. 5). Repeat the checking procedure on all corner joins.

When you're satisfied with the fit, glue and nail each side to the end. Nail through the side lining board into the end lining board edge with 30mm nails – four per corner should be enough. To help prevent the nails splitting through the side of the lining board, it's best if you drill pilot holes for each nail. Punch the nails below the surface as each join is completed. With a damp rag, wipe away any excess glue before it dries.

Step 4: Add the bottom

Cut four bottom boards 893mm long. Plane off the tongue of one of the outside boards and the groove off the other. Cut three battens 520mm long. Fit the four bottom boards together with the ends in line and even to each other.

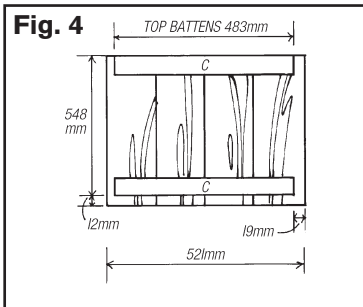
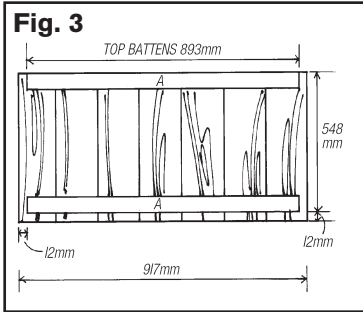

CUTAWAY OF CONSTRUCTION OF STORAGE CHEST

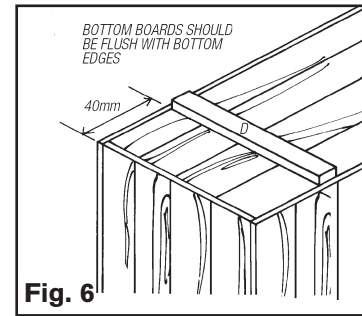
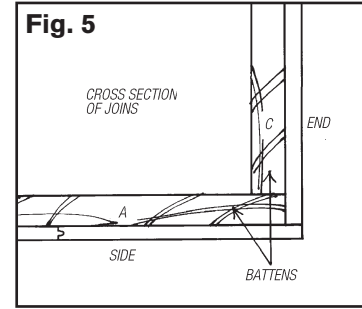
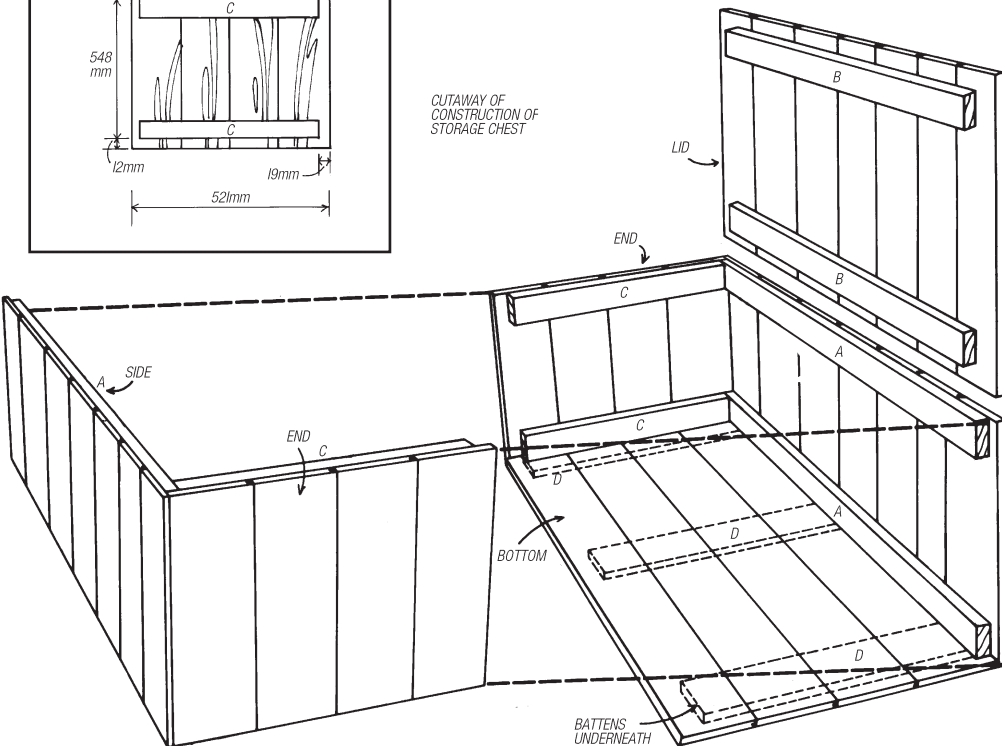

Fig. 6

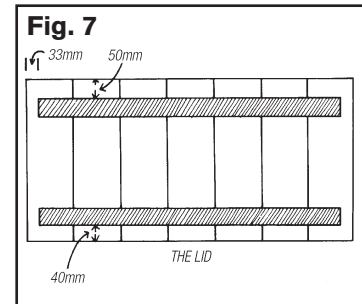

Fig. 7

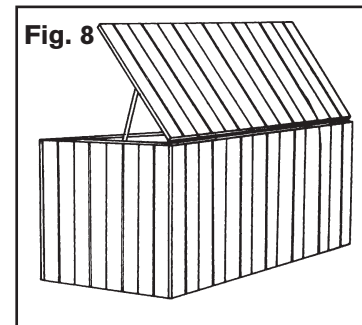

Fig. 8

Position the boards on the battens with the two end battens located 40mm in from each end and the third batten located centrally between. Glue and nail the boards to the batten with 25mm nails.

Turn the chest upside down and place the bottom panel onto the bottom battens. The surface of the bottom boards should be flush to the bottom of the outer lining boards (Fig. 6). Glue and nail the bottom panel to the battens with 25mm nails, then punch the nails below the surface.

Step 5: Now top it off

For the lid, you will need seven 545mm long boards and two 850mm long battens. Fit the boards together after planing off the outward facing tongue and groove to a smooth finish.

The two battens are nailed to the underside of the lid 33mm in from each end of the lid and 50mm in from the front edge and back edge to ensure a snug fit (Fig. 7). Place the lid on the chest to ensure all its edges are square to the chest and that it will open smoothly.

Step 6: Fit your hinge

The piano hinge is best suited to this type of lid as it provides full length fixing which will add stability to both the lid and box side. The hinge is cut 10mm less than the length of the box. This hinge sits directly on the surface and does not need recessing down (Fig. 8).

Firstly fit the hinge to the lid and check that the screws do not go through the surface of the lid. Locate the lid in position on the box, aligning it up with the four surfaces of the box. Carefully mark the location of the two extreme end hinge screw holes. Then screw the lid and hinge to the box and, with the lid held in the open position, proceed with the rest of the screw fixings.

The lid needs to have a lift-up stay (or lid stay) attached so it does not over open and tear itself from the hinge, or more importantly, slam shut on someone's fingers.

Step 7: The final touch

The final step is to fill all nail holes with a suitable wood filler, sand the entire outer surface smooth, then paint or apply a protective finish.

When sanding, be sure to sand with the grain to avoid scratching the surface, especially if you plan to use a timber stain or clear surface finish to bring out the natural beauty of the timber.

Or, if you prefer, you can paint it to add a cheerful colour to a child's room or to mix and match with existing furniture. Choose an oil based enamel paint for a hard-wearing surface that is easy to wipe clean.

Either way, remove all traces of dust before applying. And follow the manufacturer's instructions – they're there to help you achieve a professional result.

Now, all that's left is to enjoy a cup of tea while you stand back and admire your handiwork.

MIGHTY HELPFUL HINTS TO MAKE THE JOB EASIER

- When planing a board, always work with the grain and keep checking that the edge is straight with your carpenter's square.
- Measuring is easy, materials expensive. Double check all measurements and markings before you cut any piece of timber.
- When cutting several pieces of timber to exactly the same length, you will get a more accurate result by clamping them together and measuring them as one. That way, even if you're a fraction out, the pieces will still all be identical.
- Driving nails into the end of a piece of timber often causes it to split. To avoid this, pre-drill the holes first using a drill bit about three-quarters of the nail's diameter. Or, blunt the point of the nail by hitting it with your hammer – it leaves a slight burr which cuts the timber fibres rather than pushing them apart.
- When nailing, leave about 3mm of the nail standing above the surface of the board to prevent hammer marks marring the surface. Then use a nail punch to drive them fully home.
- When using any power tool, your eyes should always be protected by wearing suitable goggles.
- Some Mitre 10 stores do have a cutting service. However, if your local store does not, they may be able to order the material cut to size (CTS). So check with your friendly Mitre 10 staff member.

Build a storage chest



IMPORTANT: This project planner has been produced to provide basic information and our experienced staff are available to answer any questions you may have. However, this information is provided for use on the understanding that Mitre 10 is not liable for any loss or damage which is suffered or incurred (including but not limited to indirect or consequential loss), for any personal injury or damage to property suffered or sustained as a result of using the information contained in this MitrePlan Project Planner. Mitre 10 advises you to call in a qualified tradesperson, such as an electrician or plumber, where expert services are required, and to independently assess any safety precautions that will need to be followed prior to using the information in this MitrePlan Project Planner.

WARNING: There may be by laws or regulations of councils or other statutory bodies that you must comply with when following this MitrePlan Project Planner.

Your local MITRE 10 Store is: