

# MITREPLAN PROJECT PLANNER

Install your own shelving



- An easy-to-follow guide to achieving a perfect result.
- Outlines all the tools you will need for the job.
- Includes a materials checklist.

**PLEASE NOTE:**

Before starting this project or buying any materials, it is worth your time to read all steps thoroughly first to be sure you understand what is required.

Mitre 10 is proudly Australian owned.

**#27**

[mitre10.com.au](http://mitre10.com.au)

**MIGHTY HELPFUL™ MITRE 10**

## MIGHTY TOOLS FOR YOUR MITREPLAN

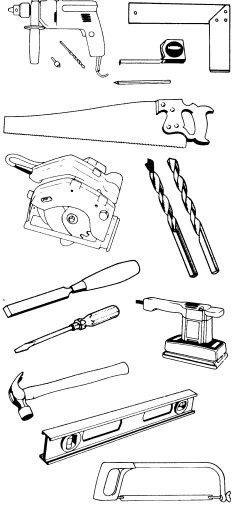

**Spirit level**

**Power drill**

**Twist drill bits  
(for cavity walls  
and timber)**

**Masonry drill bits (for  
brick or cement walls)**

**Hacksaw (for metal  
adjustable shelving)**

**Power sander**

**Screwdriver**

**Carpenter's square**

**Hammer**

**Measuring tape**

**Marking pencil**

**Wood chisels**

**\* TOOLS REQUIRED WILL  
DEPEND ON YOUR SELECTED  
SHELVING METHOD.**

## ✓ MIGHTY HELPFUL CHECKLIST

		ORDER
	Shelving – timber, particleboard, plywood or glass	
	Shelf brackets for fixed shelving	
	Shelf supports for adjustable shelving	
	Adjustable metal shelf uprights and brackets	
	Countersunk screws	
	Wall plugs for solid walls	
	Spring or gravity toggles, or expanding wall plugs for cavity walls	
	Nails – various sizes if required	
	<b>Other materials</b>	

Verbal quotes are indicative only. Written quotes on materials are available upon request from your Mitre 10 store.

### Finishing off

If you've chosen ready-to-assemble shelving that is already veneered or laminated, all you need to do now is clean up. But if you've cut your own shelves to size, they'll need to be finished. Where particleboard with a woodgrain pattern has been used, any cut front edges will need to be disguised to give a clean finish. Matching pre-glued edging that you simply iron on is available. For plain particleboard or plywood, nail on a strip of timber moulding along all edges that show before sanding and painting. Or, consider laminating them yourself – MitrePlan#8 shows you how to do it. For natural timbers, choose a clear finish to highlight the timber's true beauty. If you do want colour, a pigment stain adds it without hiding the timber's grain.

# It's easy to build shelving - with help from Mitre 10.

Practically every home could use more storage space. Somewhere to put books, records or treasured bric-a-brac. Or to store garden equipment, tins of paint and the like in an outside shed or garage. Adding extra shelves is an easy, practical and good looking way to beat the problem. So take a good look around your home for walls or nooks and crannies that could be put to good use with a simple shelf or two. Under stairs, around windows, beside the fireplace, over a door. The beauty of it is that anyone can do it. You don't need any special skills, and it needn't be expensive. Today, there's a wide variety of ways to support shelves. They can be fixed or adjustable, built in or supported on brackets. And it's so easy. All you need are the right materials, the right tools and the right advice from Mitre 10.

## Step 1: Think ahead

Think carefully about the size, weight and number of objects you're going to put on your shelves before you buy any materials. This will determine your choice of shelving material, supports and the space between them. You should think, too, about the use of the objects. Things which are used infrequently can be stored high, while everyday items should be within easy reach, say 750 to 1500mm from the floor. If you're installing a set of shelves, it's a good idea to allow an extra 20-30mm in height between them so you can remove items more easily. Where shelves are to be of different depths, the deepest should be lower so you can easily see and reach to the back. Fixed shelves are a good choice for garages, sheds and the like. But for displaying ornaments, photographs and other treasures, consider adjustable shelves that can be moved up or down whenever you feel like adding bigger or smaller items.

## Step 2: Choose your shelf

The position of your shelf usually affects the method and materials you use. Unfinished MDF board or particleboard, while probably the most economical, will need to have its edges finished with pre-glued iron-on edging or shelf moulding to give it a neater appearance. Or, you can buy it pre-cut in a variety of sizes and already finished in either a decorative timber veneer or laminated surface. Plywood is suitable for a shed, garage or workshop, but for use inside the home, you'll also need to disguise its edges. Glass is popular and is ideal for lightweight objects in living areas and bathrooms. It also comes in standard stock sizes. Natural timber is an obvious favourite. It's more expensive but very strong and easily finished. Radiata Pine is probably the most popular for shelving today and can be purchased in kit form already sanded and complete with matching pine brackets.

## Step 3: Choose your support

Once you have chosen your shelves, the next step is to decide how to support them. Supports should be spaced according to the thickness of the shelf material and its load. Heavy loads

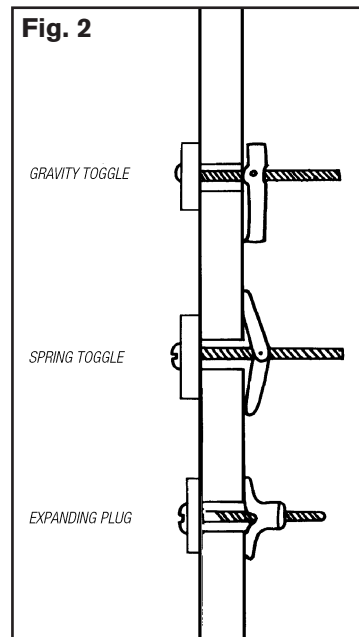
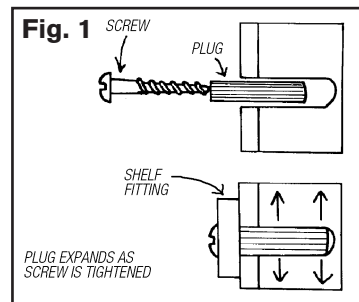

require supports spaced closer together than for light loads. There is no hard and fast method for this, but if you follow this general guide to the span you need between supports for various materials you won't go wrong.

Material	Thickness	Span
Particleboard/MDF	16mm	400-600mm
	19mm	600-900mm
Plywood	12mm	600-750mm
	19mm	600-1000mm
Softwoods (such as Radiata Pine)	19mm	750-900mm

## Step 4: Choose a firm fixing

If you're fixing shelves to a wall, you'll need to know two things. First, the strength of fixing you need – are the items to be supported heavy or light. And secondly, what kind of wall it is – solid or hollow. Either way, screws are generally used. But on their own, screws are normally not enough. You'll need something extra.

### Fixing to solid walls

There's a variety of wall plugs available for fixing into brick, stone and concrete, but they all work in basically the same way. First, drill a hole using a masonry drill bit and then insert the plug into the hole. As the screw is tightened, the plug expands and presses against the sides of the hole firmly embedding it (Fig. 1).

### Fixing to hollow walls

Screwing directly to the timber wall studs is the best way. However, if you need support between two studs, the screws have nothing solid to bite on, so support must come from inside the wall itself. Again, there are a number of fixings you can use. Toggles, whether gravity or spring type, use a small hinged device fitted at the end of a machine screw. This flops down or springs open inside the cavity as the screw is tightened, gripping the wall firmly from the rear (Fig. 2). Alternatively, expanding plugs can be inserted into the drilled hole, and as the screw is tightened, the plug bulges out behind the wall until it is too big to come back through the hole (Fig. 2).

## 8 ways to go up a wall

### Metal L-Shaped Brackets

Normally used for single shelves. They come in 150 – 600mm sizes to fit standard shelf widths. Some have an angled support linking both arms for heavier loads.

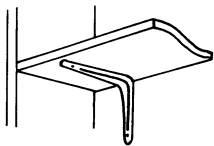

### Timber Battens

Lengths of timber batten fixed to the wall. Ideal for recesses. Batten size depends on your shelf load. For very wide spans or heavy loads, run an extra batten along the back wall.

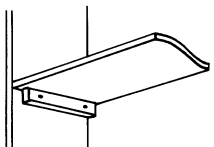

### Angled Metal Strips

'L-shaped' strips that are cut to length with a hacksaw and fixed through pre-drilled holes. They do the same job as timber battens but give a neater, less obtrusive finish.

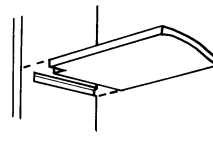

### Timber Brackets

Solid timber brackets can be purchased in a variety of decorative designs. Or you can make your own for fitting shelves in alcoves, sheds, etc.

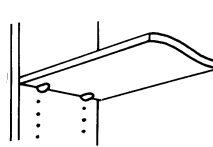

### Housing Joints

Used mainly in bookcases, cupboards or wall units. A through housing is easiest, while stopped housings give a neater finish. Refer to MitrePlan#26 on how to make timber joints.

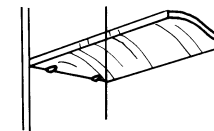

### Shelf Studs (metal or plastic)

They slot into a hole in a timber upright at each corner of the shelf. Holes are spaced equally along the length of the upright for easy shelf adjustment. Small lengths of timber dowel will do the same job.

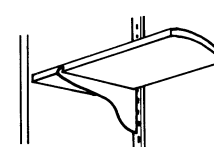

### Glass Supports

Some have a soft felt pad for the plate of glass to sit on, while others come with a slot that grips the glass. All glass shelf requirements must be carried out by a competent glazier.

### Metal Uprights & Brackets

These come in a wide range of types but are similar in principle. The upright is fixed to the wall and then the shelf bracket is slotted into position at the required height. Available in lengths from 370 – 2400mm and cut to size with a hacksaw. Brackets vary from 150 – 600mm deep.

## Step 5: Putting up shelves

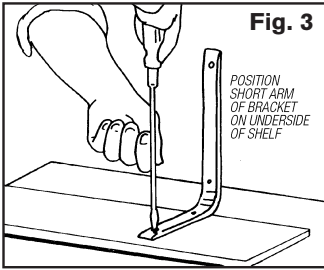

### Bracket Shelving

Lay your shelf face down and position the shorter arm of the bracket squarely on the bottom side (Fig. 3). The shelf shouldn't project more than 25mm beyond the tip of the bracket arm. When you're satisfied that it's square and will lie snugly against the wall, mark and drill holes where the screws will go. Drill your holes slightly smaller than the diameter of the screw for a firm fit. Now screw the bracket arm to the shelf. Repeat for the second bracket and any others needed.

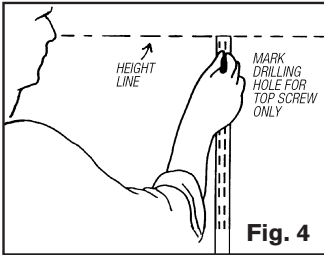

Next, using your spirit level, pencil a line along the wall where you want the top of the shelf to fit. Hold the shelf, complete with brackets fitted, along this line. If it's a fairly long shelf, you'll probably need a helper. Make pencil marks through the screw holes in the brackets. Then drill holes on these marks. If it's a solid wall, use a masonry drill bit and insert plugs. If it's a hollow wall and you're fixing with toggles or expanding plugs, use a twist drill bit and follow the instructions on the pack for the size you need to use.

Finally, hold the shelf in position, tighten one screw in each bracket to halfway only, then tighten up the whole lot.

### Adjustable Shelving

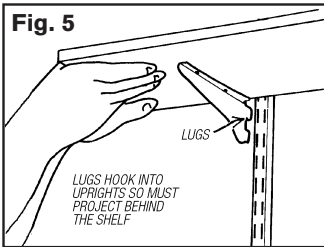

If needed, cut the uprights to size with a hacksaw. Then, with your spirit level, pencil a line across the wall where the tops of the uprights are to go. Next, measure along this line and pencil in the spacing between each upright. Start by holding an end upright in position with its top hard up against the height line. Mark a drilling hole through it for the top screw only (Fig. 4). Drill the hole, plug if necessary, and loosely tighten the screw.

With the upright hanging loose, hold your level against it and bring it into vertical line. Mark drilling holes for the other screws, then swing the upright aside and drill, plug and insert screws. Tighten all screws including the top one. Repeat for the other end upright and any others required. Then cut and fit the shelves. Shelving can be fitted to some systems without requiring screws to hold them in place on the brackets. Others need to have the brackets screwed to the bottom of the shelves. In this case, make sure the brackets are fixed square and that the lugs which hook into the upright, project behind the shelf (Fig. 5).

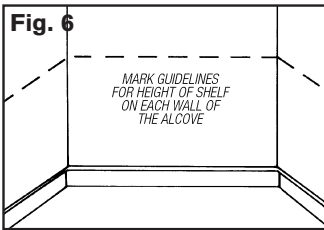

### Alcove Shelving

Alcove shelving supported on wooden battens is a simple, effective way to utilise what is often wasted space. It's vital to get the batten level, so start by marking guidelines for the height of each shelf on all three walls using your spirit level (Fig. 6). If the alcove width is fairly small, you may only need battens for the two side walls. Cut these slightly shorter than the depth of your shelves. Where the shelves span a wide alcove, or have a lot of weight to carry, measure and cut a batten to span the back wall too (Fig. 7). Drill holes in the battens about every 450mm. Then mark and drill corresponding holes in the wall, insert plugs and fasten with screws. If you like, nail a batten to the front edge of your shelves. This will not only make them stronger, but will also give a neater, more natural timber look if you're using particleboard or plywood. It will also help to hide the ends of the side wall battens.

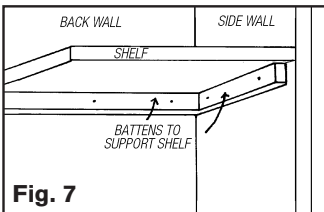

# Install your own shelving

## MIGHTY HELPFUL HINTS TO MAKE THE JOB EASIER

■ Prior to drilling into any wall, it's vital that you check thoroughly for electrical wiring, plumbing or gas pipes which may be below the wall surface.

■ Measuring is easy, materials are expensive. Double check all measurements and markings before you cut any piece of timber.

■ Shelf supports should be chosen to suit the load you intend the shelf to carry.

■ The front edge of a shelf should not extend more than 25mm beyond the end of its bracket support.

■ Space supports according to the shelf thickness. Heavy loads need closer spacing than light loads.

■ Consider screw gauge as well as length – 6 gauge for light fixings only, 8 gauge for most jobs and 10 or 12 gauge for a very sound fixing.

■ When drilling into walls, wrap a piece of sticky tape around your drill bit, to mark the length of the plug – when the tape touches the wall, you know you've gone far enough.



**IMPORTANT:** This project planner has been produced to provide basic information and our experienced staff are available to answer any questions you may have. However, this information is provided for use on the understanding that Mitre 10 is not liable for any loss or damage which is suffered or incurred (including but not limited to indirect or consequential loss), for any personal injury or damage to property suffered or sustained as a result of using the information contained in this MitrePlan Project Planner. Mitre 10 advises you to call in a qualified tradesperson, such as an electrician or plumber, where expert services are required, and to independently assess any safety precautions that will need to be followed prior to using the information in this MitrePlan Project Planner.

**WARNING:** There may be by laws or regulations of councils or other statutory bodies that you must comply with when following this MitrePlan Project Planner.

**Your local MITRE 10 Store is:**