

# MITREPLAN PROJECT PLANNER

## Roof guttering ≠ maintenance



- An easy-to-follow guide to achieving a perfect result.
- Outlines all the tools you will need for the job.
- Includes a materials checklist.

### PLEASE NOTE:

Before starting this project or buying any materials, it is worth your time to read all steps thoroughly first to be sure you understand what is required.

Mitre 10 is proudly Australian owned.

# #73

[mitre10.com.au](http://mitre10.com.au)

**MIGHTY HELPFUL™ MITRE 10**

## MIGHTY TOOLS FOR YOUR MITREPLAN

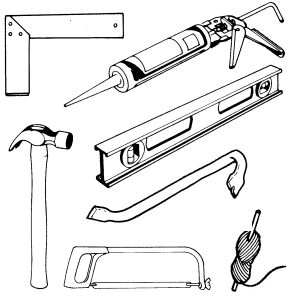

### METAL ROOF, SPOUTING, DOWN-PIPES

Tin snips  
Hammer  
Cordless screw-driver & hex head bit  
Drill bits  
Silicone gun  
Square  
Pinch bar  
Hack saw  
Spirit level  
String line  
Pop rivet gun

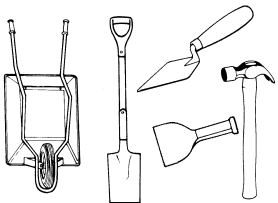

### TILE ROOF

Wheel barrow  
Spade  
Brickies trowel  
Hammer  
Small cold chisel

## MIGHTY HELPFUL CHECKLIST

All metal products are available in colour bond or natural finish.

	ORDER
<b>Spouting</b>	
Spouting	
Spouting clips (1 per metre) & nails	
Pop rivets	
Silicone	
Stop ends	
Internal corners	
External corners	
Mineral turpentine	
Rags	
Down-piping	
Pre-formed eaves angles	
Down-pipe clips	
Down-pipe pops	
Pop-rivets	
<b>Tile roof</b>	
Brickies sand	
Cement	
Limil	
Colour additive	
Ridge capping	
Roof tiles	
Flashing (and pre-formed)	
<b>Metal roof</b>	
Roofing	
Roof nails/ hex head screws	
Silicone	
Pop rivets	
Flashing (and pre-formed)	
Mineral turpentine	
Rags	

Verbal quotes are indicative only. Written quotes on materials are available upon request from your Mitre 10 store.

## Keep a safe roof over your head - with a little help from Mitre 10.

Roofing problems are a problem in most homes at some stage or other, and very often with just a little know-how and assistance from Mitre 10 the problem can be easily solved. Here we cover several of the most common roofing maintenance areas.

### Plan ahead

Since roof work can expose the house to prevailing weather it is best to carefully plan what the job will entail in time, sequence of work, and materials. With a carefully detailed plan you will be in a position to purchase all the required materials prior to commencement and have a work schedule to guide your time.

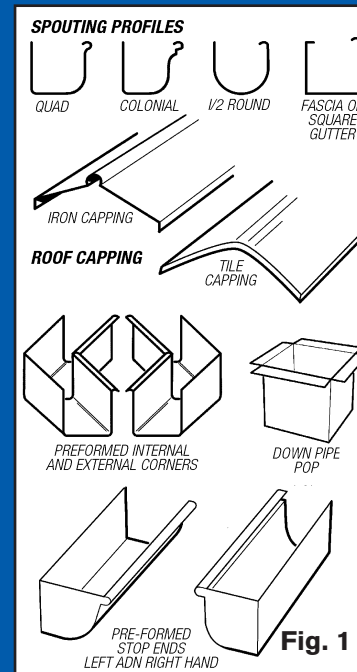

### To make the job easier

In roof plumbing joins, flashing laps and spouting laps are overlaid and lapped in the direction of the flow of water from the top downwards (Fig. 2).

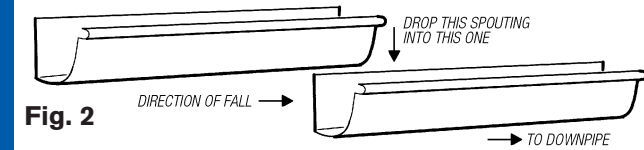

In some maintenance instances, pop rivets will need to be removed. This is done by drilling the pop rivet out with a suitable size drill bit or using a medium sized flat bladed screw driver and hammer and knocking off the head of the rivets.

Paint will not adhere to silicone so remove all external traces of silicone with a rag moistened with mineral turpentine.

## SPOUTING

### Step 1: Investigating

Firstly find out whether the existing spouting profile is available. Be careful though as what may look the same could in fact be marginally different in size and profile to your existing. It is best to take either a piece of the spouting or one of the spouting clips to your Mitre 10 store. If you are able to match the exact profile then you will not need to remove and replace the spouting clips, unless of course the existing spouting has no fall to the drainage point.

Prior to accessing your roof, wrap some cloth around the top of your ladder ends so the spouting does not get scratched. Then place a piece of timber inside the spouting where the ladder is going to be placed so the pressure of weight does not distort the line of the spouting (Fig. 3). Spouting may be available to order at some Mitre 10 stores.

### Step 2: Removing existing

First task is to release the pop rivets which are holding the joins, corners and perhaps the spouting brackets and spouting together. It may be necessary to cut the spouting to facilitate removal. This is done with a hacksaw or tin snips; do not use an angle grinder. The spouting will have been fixed to the fascia board by spouting brackets and nails. To remove the spouting bend the clips at the outer upper lip of the spouting bracket upwards (Fig. 4), then rotate the spouting off the bracket. Remove the spouting clips with your pinchbar.

### Step 3: Setting out

To create water flow to the down-pipe or outlet the spouting needs to be placed out of level and the rate of fall should be around 15-25mm per 10 metres. To create a straight line, run a string line out from one end to the other, stretch it tight and check that it has the correct amount of fall with a spirit level (Fig. 5). Place the spouting brackets at one metre spacings using the string line as a guide to the horizontal position.

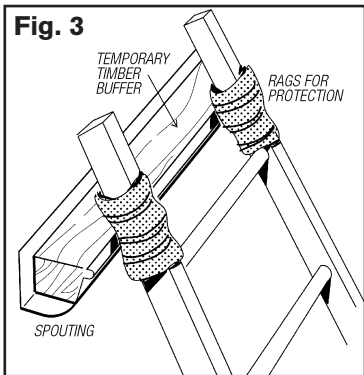

Pre-formed internal and external corners can be purchased for most spouting profiles, however for certain profiles and colours these may need to be made to order, so allow time in your ordering for this. Make a note of where the down pipes are located and cut and fit the down pipe pops into the spouting prior to putting the spouting up (Fig. 6). Silicone seal between the pop flange and the spouting, press the pop into place and the pop rivet the flanges to the base of the spouting.

### Step 4: Fitting the spouting

Commence laying the spouting from the lowest (down pipe end) point, this way the joint laps will be layered so the collected water runs over the top of the joints and not into them. Measure along the fascia board for the length of spouting required, add to the length an allowance for a 20mm lap joint into adjoining spouting and also the internal or external corners. Cut the spouting to length using your hacksaw or tin snips (do not use an angle grinder). Silicone and join the pre-formed corner to the spouting with pop rivets, use 4 pop rivets per joint.

Squeeze some silicone around the inside of the overlapping end of any joining spouting. Place the spouting onto the fascia clips and position with the 20mm lap into the adjoining spouting. Press the spouting firmly into place, bend over the restraining tags on the spouting brackets and drill and pop rivet the joints. Clean any excess silicone off the face of the spouting and smooth out any silicone buildup inside the joint.

## DOWN PIPES

### Step 1: Removal

Remove down pipe clips, and release any pop rivets at joints or the down pipe pop. One section of down pipe should be able to be slid down over the other to free it.

### Step 2: Fitting down pipe

One end of the down pipe is larger in dimension than the other. This is the top section in all instances and allows one piece to fit inside the other and to a certain degree helps length adjustment. Join lap should be a minimum of 40mm.

Silicone is not used on the down pipe joints. Commence installation at the top with the spouting, joining and adjusting the length of the eaves bends. Measure, cut and fit the remaining lengths of down pipe. Place a down pipe clip over each joint, and secure to the wall with screws or clouts (Fig. 7).

## LOOSE RIDGE & HIP CAPPING TILES

### Step 1: Removing & cleaning

Take a bucket up onto the roof with you so all debris can be cleaned as it accumulates. To save breakage of tiles carefully tap the mortar joint between the tile and capping tile with a cold chisel. Once the tile is loose remove the old mortar from all surfaces.

### Step 2: Bedding joint

Mix up enough mortar for the job, at the rate of 4 sand, 1 cement, 1 limil. Add colour pigment to the mix if needed. This is to be in strict accordance with manufacturer's instructions as too much will weaken

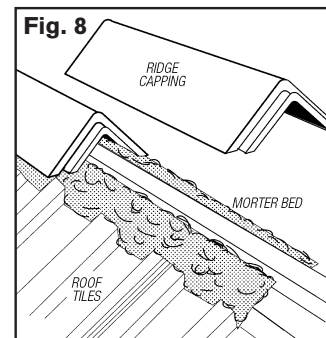
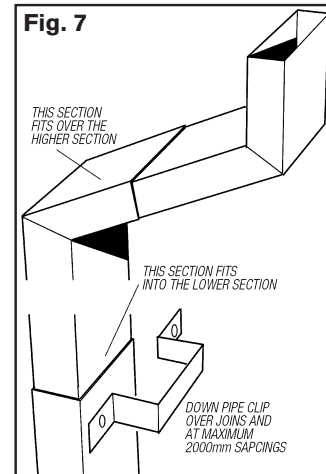
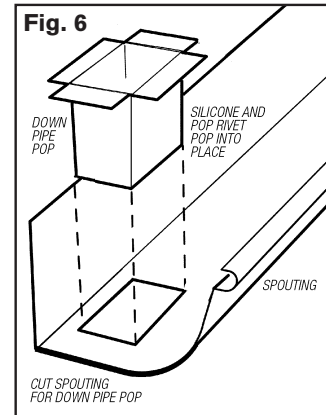
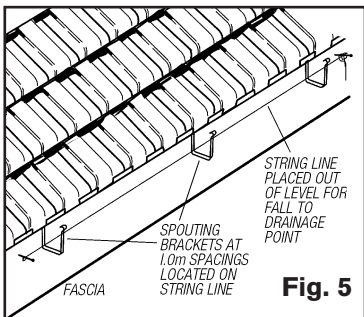
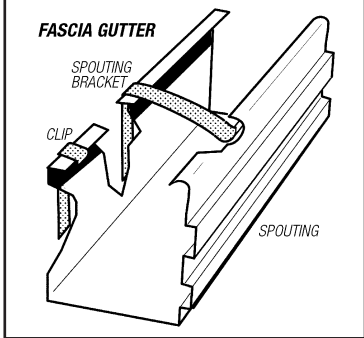
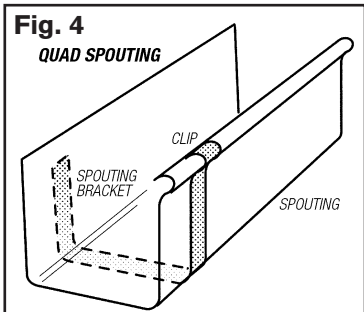

the bed joint. Add water to create a thick creamy substance. Place some of the mixture in a bucket and take it up on the roof. Mark the outer edge line of the capping tile onto the roof tiles, and with the brickies trowel spread a bed of mortar about 50mm x 50mm along the inside of the marked line. Carefully press the ridge cap into the mortar bed until the correct height has been obtained (Fig. 8), progressively overlap and lay the rest of the tiles.

Clean excess mortar off along the edge line of the tiles to leave a full clean bed of mortar.

## CHIMNEY FLASHING

Chimney flashing generally lasts pretty well, but where it needs replacing use the existing flashing as a pattern to either bend up your own from 16 gauge zinc alum or galvanized iron, or get some bent for you through your local Mitre 10 store. (Some stores may not offer this service.)

The various components of a typical chimney flashing system and how they fit around the chimney are shown in Fig. 9. There is only one correct way to proceed here, and that is in the sequence mentioned in 'To make the job easier'.

The flow of all water must be over the top of all laps, so laying of the flashing must commence at the lower point of the area to be flashed. First install base flashing, 'A' the top lip being pressed into the brick course by 10mm and a bead of silicone to seal this lip to the brick course. Next install side flashings 'B' and 'C', silicone seal the lip into the brick course and silicone and pop rivet the tray overlap to the base flashing.

Finally the top rear flashing 'D' is installed, this flashing tucks under the roof tiles and also the top lip fits into the brick course and is silicone sealed. The tray extends out over the top of the side flashings and is silicone sealed and pop riveted for a weather tight seal.

Clean off all excess silicone before it dries.

## METAL ROOFS - LOOSE SHEETS

Corrugated iron sheets fixed down with roofing nails will inevitably become loose over time. The easiest surest way of securing this problem is to remove the offending nail and replace with roofing screws. These are a 50mm long hexagonal headed screw with a rubber washer (Fig. 10). Using a matching driver bit in a cordless drill insert the screw into the hole left by the nail and tighten down securely. In no circumstance put nails or screws in the lower section of the corrugation.

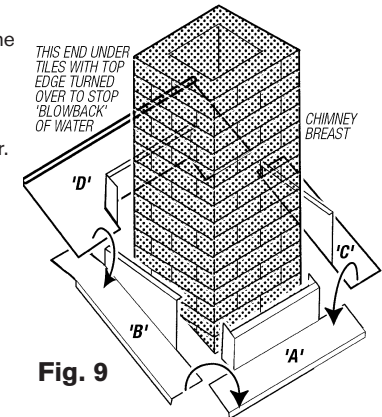
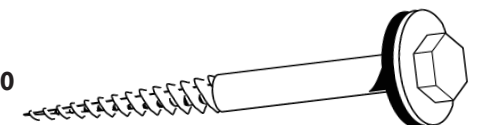

Fig. 10



## MIGHTY HELPFUL HINTS TO MAKE THE JOB EASIER

### SAFETY

- Do not work on damp roofs, they are extremely slippery.
- Do not work in the vicinity of any electrical cables.
- When working from a ladder or set of steps do not over-reach beyond maintaining a vertical posture on the ladder.
- Hire a scaffold where the height of the work is 2.4 metres or more off the ground.
- Wear safety glasses or goggles at all times.
- Wear full footwear at all times (sneakers are ideal on a roof), no sandals.
- When walking on a tile roof step on the nose of the tile, not mid-body.
- When walking on a metal roof step on the nails, as this is where the roof battens will be.

# Roof guttering ≠ maintenance



**IMPORTANT:** This project planner has been produced to provide basic information and our experienced staff are available to answer any questions you may have. However, this information is provided for use on the understanding that Mitre 10 is not liable for any loss or damage which is suffered or incurred (including but not limited to indirect or consequential loss), for any personal injury or damage to property suffered or sustained as a result of using the information contained in this MitrePlan Project Planner. Mitre 10 advises you to call in a qualified tradesperson, such as an electrician or plumber, where expert services are required, and to independently assess any safety precautions that will need to be followed prior to using the information in this MitrePlan Project Planner.

**WARNING:** There may be by laws or regulations of councils or other statutory bodies that you must comply with when following this MitrePlan Project Planner.

**Your local MITRE 10 Store is:**