

## MIGHTY TOOLS FOR YOUR MITREPLAN

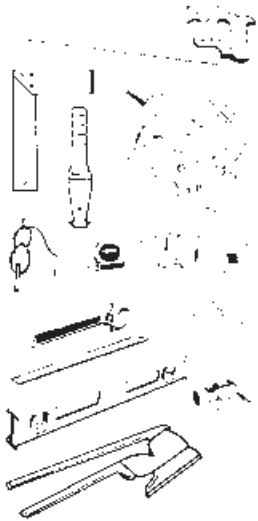

Circular saw and/or hand saw  
(for cutting timber)  
Electric drill and bits set  
Tungsten-tipped 'score and snap' knife and/or hand guillotine  
(for cutting Hardiflex)  
Claw hammer  
Carpenter's square  
Spirit level  
Builder's stringline  
Adjustable spanner  
Measuring tape/rule  
Pencil  
Concreting tools

## MIGHTY HELPFUL CHECKLIST

	ORDER
<b>Framework – Radiata pine stress grade F5 MGP10 – 70 x 35mm</b>	
Top/bottom wall plates	4/3.6 4/2.1
Studs	27/2.4
Noggings and trimmers	4/3.0
Roof battens	4/3.6
Radiata pine F5 MGP10 rafters – 140 x 35mm	5/2.4
Treated pine fascia board – 190 x 32mm	2/3.9 2/2.4
<b>Wall Lining – Hardiplank</b>	
300mm Woodgrain or smooth	24/4.2
300mm Aluminium external corners	34
90 x 19mm Hardwood door frame	1/900mm 2/2.1m
Exterior grade ply door – 2040 x 820mm	1
Architraves 42 x 19mm	
1 – 1200mm length	
2 – 2100mm lengths	
<b>Roofing</b>	
Corrugated iron roof sheets 5 – 2400mm	
Barge/fascia capping 2 – 2400mm lengths	
1 – 3600mm length	
Guttering and accessories (as required)	
<b>Concrete Floor</b>	
Refer MitrePlan#31 'Laying concrete'	
<b>Hardware</b>	
Dynabolts (or similar) 10 – 60 x 8mm	
Bullet head nails 5 kg – 75mm long	
Bullet head nails 0.5kg – 50mm long	
Galvanised clouts 0.5kg – 40mm long	
Galvanised fibre cement nails 2kg – 40mm long	
Galvanised roofing nails or screws 1kg – 60mm long	
Trip-L-Grip connectors x 10	
Metal angle wall bracing 6 – 3000mm lengths	
Aluminium flashing 1 – 20m roll 150mm wide	
Butt hinges and screws 1 pair 75mm	
Door lock or latch	
1 tube silicone roof sealant	

Verbal quotes are indicative only. Written quotes on materials are available upon request from your Mitre 10 store.

## MIGHTY HELPFUL HINTS TO MAKE THE JOB EASIER

■ When cutting several pieces of timber to exactly the same length, you'll get more accurate results by clamping them together and measuring them as one. That way, even if you're a fraction out, the pieces will still all be identical.

■ Noggings can be skew nailed to studs in a straight line. Or, for easier nailing, stagger them by driving two nails through the studs into each nogging at each end.

■ Ensure Hardiflex sheets are completely dry before fixing. And stack them on their edges or lay them flat on a smooth, level surface to prevent the corners from chipping.

■ When forming holes, ensure that the sheet edges are properly supported to avoid damage.

■ Remember, a building permit will probably be required. Check with your council first about local regulations.

# Build a great garden shed



**IMPORTANT:** This project planner has been produced to provide basic information and our experienced staff are available to answer any questions you may have. However, this information is provided for use on the understanding that Mitre 10 is not liable for any loss or damage which is suffered or incurred (including but not limited to indirect or consequential loss), for any personal injury or damage to property suffered or sustained as a result of using the information contained in this MitrePlan Project Planner. Mitre 10 advises you to call in a qualified tradesperson, such as an electrician or plumber, where expert services are required, and to independently assess any safety precautions that will need to be followed prior to using the information in this MitrePlan Project Planner.

**WARNING:** There may be by laws or regulations of councils or other statutory bodies that you must comply with when following this MitrePlan Project Planner.



Your local MITRE 10 Store is:

# MITREPLAN PROJECT PLANNER

## Build a great garden shed



- An easy-to-follow guide to achieving a perfect result.
- Outlines all the tools you will need for the job.
- Includes a materials checklist.

### PLEASE NOTE:

Before starting this project or buying any materials, it is worth your time to read all steps thoroughly first to be sure you understand what is required.

Mitre 10 is proudly Australian owned.

# #38

mitre10.com.au

# Build your own garden shed – with help from Mitre 10.

Every backyard needs a garden shed. It can help free up space in the garage by providing storage for the lawn mower, garden tools, wheelbarrow and fertilisers. Or, to use as a poolside storage and dressing room, workshop or even a cubby house for the kids.

So here's a simple, dry shed to build that is well within the scope of the average handy person. It is 3600mm long and 2100mm wide. The timber wall frames are prefabricated on the ground, then simply fixed to the concrete floor and each other. Wall cladding is Hardiflex fibre cement sheeting, which is ideal because it won't burn or rot and it's easily painted. You may need a building permit, so before you begin, ask your local council about any regulations that may apply.

Then all you need are the right tools and materials – with this MitrePlan to guide you – and you're on your way.

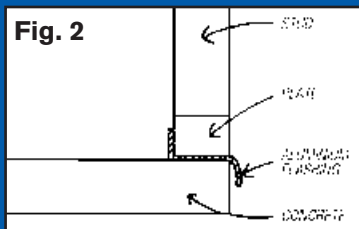
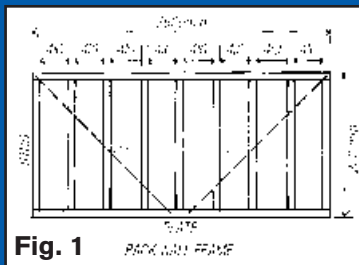

## Step 1: Groundwork

Begin by measuring and preparing a level ground surface 3600 x 2100mm for the concrete floor. Construct timber formwork all around for a 75mm thick slab. Place reinforcing steel in place on special bar chairs to keep it a constant 30mm from the surface. Then pour your concrete. For step-by-step guidance, refer to MitrePlan#31 'Laying concrete' – it tells you everything you need to know about tools, materials, formwork, mixing, laying and levelling.

## Step 2: Wall Frames

Wall frames are constructed on the ground, then erected. For the back wall, start by cutting the 3600mm long top and bottom wall plates to size. Then cut nine studs to 2030mm lengths to allow for the thickness of the two plates for a total rear wall height of 2100mm.

Using 2 x 75mm nails, nail the two end studs to the top and bottom plates. Nail the other studs in the same way at 410mm spacings. (Fig. 1)

Make the wall frame square by measuring diagonally from corner to corner. When both measurements are the same, the frame is square. Cut the bracing into the plates and studs starting from the top outer corner of the frame and run down towards the centre of the bottom plate. Set the bracing at no less an angle than 45 degrees and no steeper than about 60 degrees. Nail the brace on the bottom plate with a 40mm clout, then nail halfway along the length into a stud – but do not drive the nail completely home. This nail will be removed once all the frames are standing so you can push the frame to a final plumb position, once plumb the brace will be nailed to each stud.

To erect the frame, first lay a damp course of a continuous strip of flashing along the concrete edge and place the frame on it (Fig. 2). Brace the frame with support timbers to keep it perfectly vertical. Measure in 250mm from each corner and drill holes through the bottom wall plate into the concrete and fix with heavy duty masonry anchors (Dynabolts or similar). Centre two more anchors between these for a solid, secure fastening. Finally, to keep studs straight and stiff, nail timber noggings between studs (Fig. 3).

## Step 3: End Walls

The end walls are made in the same manner as the back wall, except the top plate is set at an angle to match the height of both the rear wall and the higher front wall. The end walls are a mirror image of each other, so follow these measurements for both walls.

Cut the bottom plate to 1960mm long and the top plate to 1973mm long. Cut the studs to length as shown in Fig. 4. Nail the two end studs to the ends of the plates and carefully place and nail the intermediate studs at spacings of 446mm measured on the bottom plate. Keep the studs parallel to each other (do not measure this spacing on the top plate as it will be running at an angle). Square the bottom plate to the end studs and cut and fit one length of metal bracing from top plate to bottom plate as done on the rear wall frame.

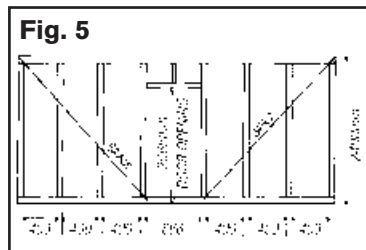
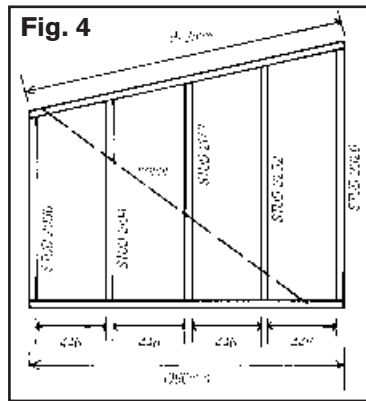
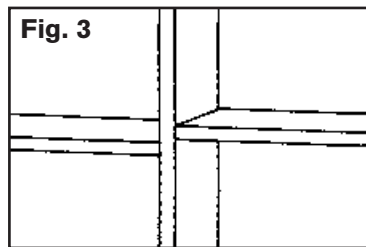
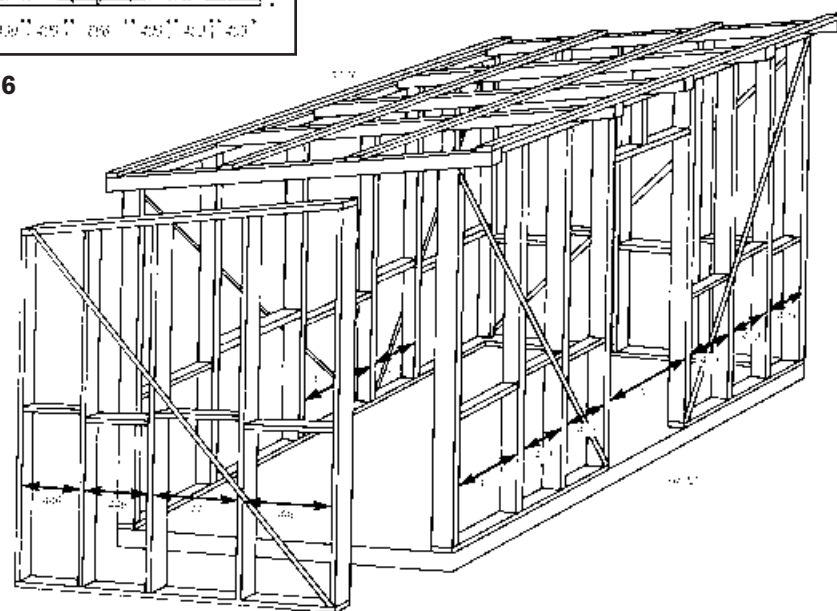

Fig. 6



Lay out the aluminium flashing, stand the wall frame in position, and nail the end stud into the rear wall frame and stud. Secure the bottom plate to the slab with two masonry fixings. Now build and erect the opposite end wall frame.

## Step 4: Front Wall

The front wall is 2400mm high and built and erected in the same way (Fig. 5). But, because it has a door in the middle, only eight 2330mm long studs are needed. First, mark the centre of the wall plate. Then mark 433mm each side of the centre line to allow for the 820mm door, door jamb and door clearance (a total of 866mm). Nail the studs to the wall plates, starting with the two end ones, and using the spacings shown (Fig. 5). For the door opening height, measure up 2065mm from the bottom plate and cut and nail a 866mm head piece. Then fix a 230mm trimmer between the plate and the head piece. As with the last wall frame, square the frame and cut and nail on the metal bracing.

Stand this final wall in position on the flashing, nail the corner studs together and fix the bottom plate to the slab with the masonry anchors.

With all the walls securely fixed together in position, loosen off all the braces and using a level on the external corners make the walls plumb. When this has been done nail all the braces at each stud and plate point with the 40mm galvanised clouts. Finish the wall frames by placing one row of noggings between all studs at mid height (Fig. 6).

## Step 5: Add the roof

The corrugated roof is supported by five 140 x 35mm rafters cut to 2300mm long. One is positioned at each end flush to the outside of the wall frame, then three intermediate rafters are set at 856mm spacings. The end of the rafters hangs over the front and rear wall frame by 100mm. Nail them to the top plates with Trip-L-Grip connectors (Fig. 7).

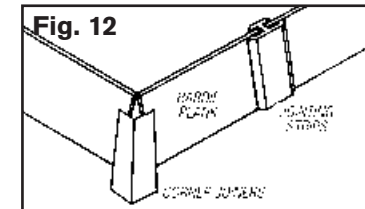
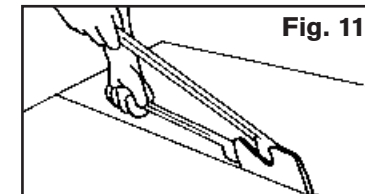
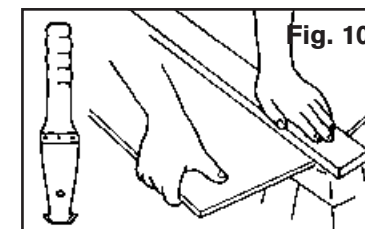
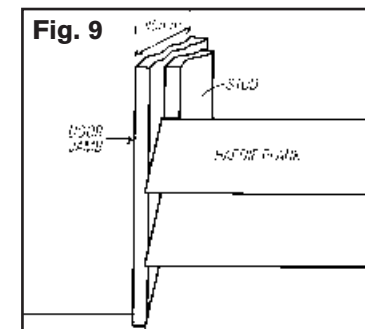
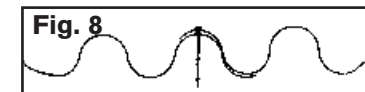
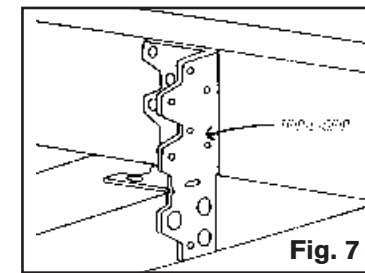

Cut the 70 x 35mm roof battens to length and space equally on the rafters. Nail the four battens to the top of the rafters with 2 x 75mm nails per fixing point.

Cut and nail the fascia boards to the perimeter of the roof. All corners should be mitre cut at 45 degrees to provide a neat joint. The top of the fascia should line up with the top of the roof battens. Fit the spouting prior to installing the roof. The spout should have a fall from one end to the downpipe to provide water run-off.

The corrugated roofing is now fixed to the roof battens. Lay out lengths of building paper as you fix the corrugated roofing, nailing through the uppermost part of the corrugation, not in the valley (Fig. 8). Next cut and fix the fascia capping to the roof so that all joints overlap by 25mm. The capping is fixed to the roof battens and fascia board and all joints should be sealed with silicone sealant.

## Step 6: Fix the lining

Cut the 90 x 19mm hardwood door frame and nail into the door opening. The frame is to protrude out beyond the outside surface of the stud by 15mm – this allows the lining to butt against the door frame (Fig. 9). Next, fit the door. Refer to MitrePlan#21 'Hanging a timber door' for full details on this.

### Cutting

There are three suitable hand methods:

1. Using a special tungsten-tip 'score and snap' knife, score from the face side of the sheet against a straight edge, repeating the action to a depth of about 1/3 sheet thickness. Then snap upwards to break (Fig. 10). You can use a power saw for this cut which will save time.
2. If using a hand guillotine, cut on the offcut side to allow for the blade's thickness (Fig. 11).
3. Hand sawing is also suitable.

### Fixing

Establish a level line around the building 30mm below the plate. This will place the line on the edge of the concrete slab. Cut and nail the Hardiplank onto the studs so it sits along this line. The corners are joined using Hardiplank pre-formed corners, and lengths can be joined between studs by using Hardies Plastic Jointing Strips (Fig. 12), so there will be virtually no material wastage. Each Hardiplank should have a 25mm minimum overlap on the board below it. Take care to keep all boards straight and parallel to the top of the wall as you work from the bottom to the top. Either get a friend to help hold the planks as you nail, or simply place a starter nail at the point of coverage to rest the plank on.

### Finishing Off

While Hardiflex needs no protection, painting it will certainly help your shed blend in with its surroundings. Only two coats of water-based acrylic paint are required – no sealing, priming or undercoat. You now have a very solid, attractive and functional shed. All that's left to do is fix shelving and hooks – Mitre 10 stores carry a variety of ready-made shelving systems which are easily installed. Or you could add a workbench (refer to MitrePlan#4).