

MITREPLAN

Construct a timber gate



PROJECT PLANNER

An easy-to-follow guide to achieving a 10/10 result.

Outlines all the tools you will need for the job.

Including materials checklist.

PLEASE NOTE:

Before starting this project or buying any materials, it is well worth your time to read through all steps first to be sure you understand what is required.

Mitre 10 is proudly Australian owned.

No. 32

www.mitre10.com.au

MITRE 10

It's easy to make a 10/10 entrance – with a little help from Mitre 10.

Your front entrance gives visitors their first impression of your home. And you can make it a grand one with a stylish timber gate. A timber gate has an attractive, natural appearance that suits both timber and brick fences (refer to MitrePlans 3 and 23). It provides privacy and security, and keeps the kids and dogs in (or out) at a low cost. Just as importantly, it will last a long, long time. Of course, you can buy one ready-made. Or buy just the frame and cover it yourself with your selected cladding. But this can be expensive, especially if standard stock sizes will not fit the opening. And making your own grand entrance isn't all that difficult. Most gates are based on a simple timber framework of vertical posts, horizontal rails and a diagonal brace. It doesn't matter what type of fence cladding you use either – the frame is the same. So go to it. All you need is a little time and average do-it-yourself skills, the right tools and materials, and this step-by-step guide from Mitre 10

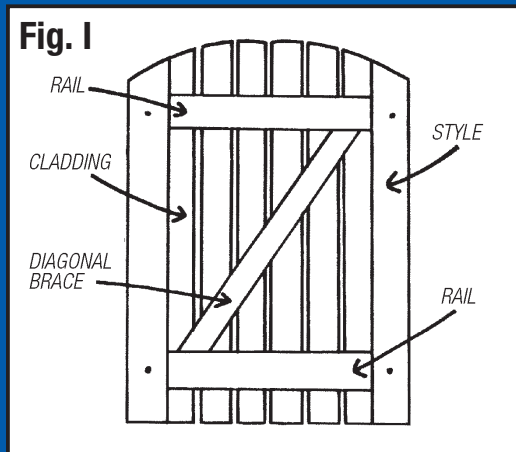

Step 1: Plan ahead

The first thing to understand is what some of the terms we'll be using actually mean (Fig. 1).

Stiles: The vertical posts on each side of the frame.

Rails: The crossmembers at the top, middle and bottom.

Diagonal Brace: Transfers the weight of the frame back to the gate post with the hinges.

Cladding: Pickets, palings, boards, etc.

You'll also need to decide the method of construction you want to use. This helps determine the materials you need. For example, the Mortise and Tenon method uses stiles to hold the gate frame rigid while the Ledged and Braced method relies on the cladding itself to do the job (saving time and materials). Mortise and Tenon is the superior method and, while a bit more difficult to make, will give you many trouble-free years.

Step 2: Measuring up

Making the frame is a straightforward matter. Simply measure the actual height from the top of the post to the ground and the fill width of the gate opening. Then subtract 50-75mm from the height for ground clearance, and, for side clearance, subtract 20mm (for double gates) or 10mm (for single gates) from the width (Fig. 2).

To calculate the number of cladding boards or pickets needed, simply divide the width of the cladding pieces into the gate opening, remembering to allow for the appropriate clearance. However, if you plan to space them apart, decide on the amount of space you want between them and then multiply it by the number of boards or pickets, less one. Next, subtract this figure from the opening and divide again by the width of the cladding. This will tell you how many boards or pickets you need, but you may have to adjust the spacing and recalculate so that you come up with a number of whole boards. Your gate will not look as attractive if you have to vertically cut a board or picket to make it fit.

Step 3: Making the frame

Mortise and Tenon

In making a mortise and tenon joint, the end of one piece of timber is cut to form a 'tongue' which is then fitted into a matching slot in the side of another piece. The 'tongue' is the tenon and the mortise is the slot (Fig. 3).

There are a number of variations, but the one used in gate construction is known as Barefaced Mortise and Tenon. The tenon is cut with only one side shoulder instead of two (Fig. 4).

Making the tenon. Start by making out the tenon on both ends of each rail. Lay the stile on the rail and score a line where the tenon starts with a utility knife and carpenter's square (Fig. 5).

Allow about 5mm longer than the width of the stile – this is cut or planed off later giving a flush neat finish.

Next, set your marking gauge to half the width of the rails and score a line across the end of the rail and down both sides (Fig. 6).

Clamp the rail to a workbench or in a vice and cut down to the baseline.

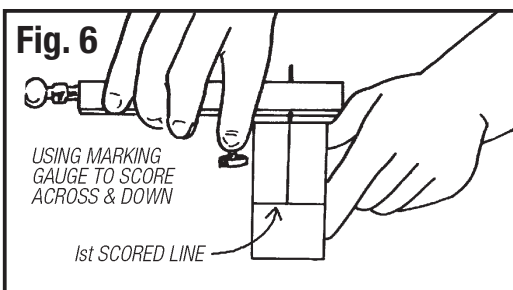
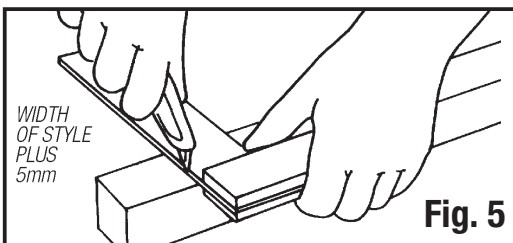
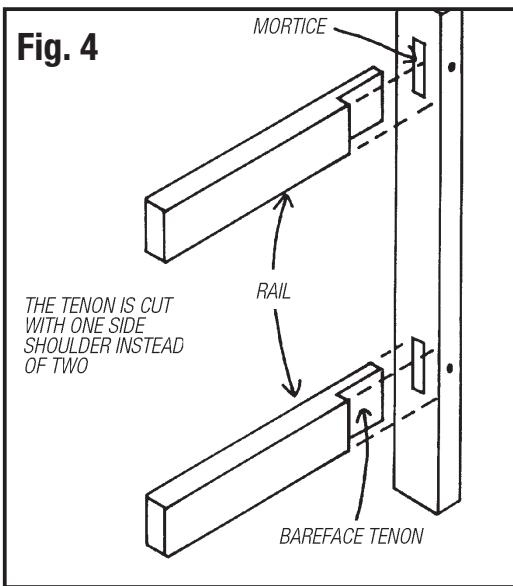
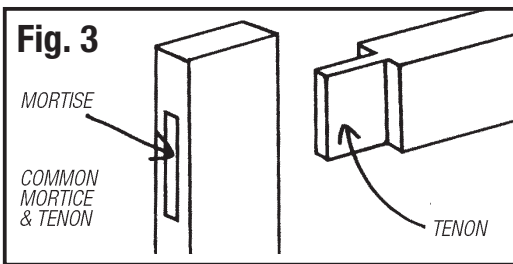
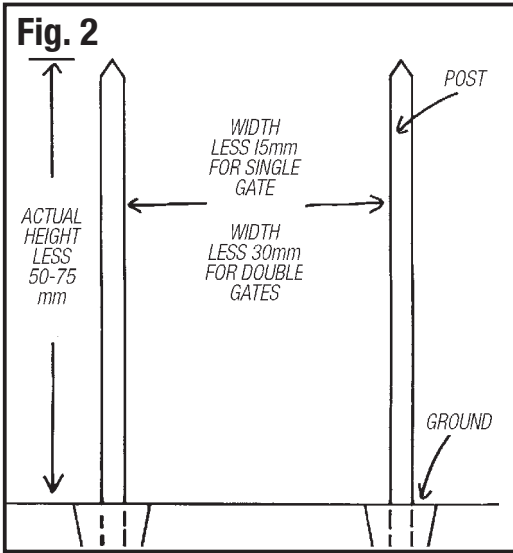

Now lay the rail flat and cut along the base line across the face to remove the waste. Clean off the tenon with a sharp chisel if necessary.

Making the mortise. Now mark out the positions of all rails on the stiles. Remember for gates higher than 1.2m, you'll need a middle rail as well as a top and bottom rail. Lay the tenon on the stile and mark the tenon's width on both faces of the stile. Square the lines across with a carpenter's square and utility knife. Then set the marking gauge to the overall width of the rail and score a line on both faces of the stile between the rail's two width lines. Next, re-set the marking gauge to the width of the tenon and score a second line to give the mortise's width (Fig. 7).

Using a drill bit slightly smaller than the mortise's width, drill holes to remove the bulk of the mortise. It's best not to drill all the way through. Instead, turn the stile over and finish the hole by drilling from the opposite side. Then clean out the mortise with a chisel, working carefully from each side.

Assembling the joint. Drill a hole the size of the dowel through the centre of the mortise from each side. Fit the joint together and mark the hole's position on the tenon inside. Then take the tenon out and drill a dowel hole through it about 2mm closer to the shoulder than your mark. Reassemble the joint and drive a tapered dowel through it. The tenon should draw up tightly to the stile and give a long lasting joint without the need for nails, screws or glue.

Now check that the frame is square by running a tape measure across the diagonally opposite corners. If they're both the same length, it's square. If not, exert pressure on the longer diagonal and brace temporarily to hold it square. Then fit the permanent brace with its lower end on the hinge side of the frame to ensure its weight is transferred to the post side. Finally, remove the temporary brace and cut or plane off any protruding tenons or dowels and sand smooth.

Ledged and Braced

Measure the width of the gate, and cut the top, bottom and middle rails to length as detailed in Step 2. Clamp the rails together, making sure the surface the picket will be fixed to is facing upwards. Mark the cladding board on picket spacings as detailed in Step 2.

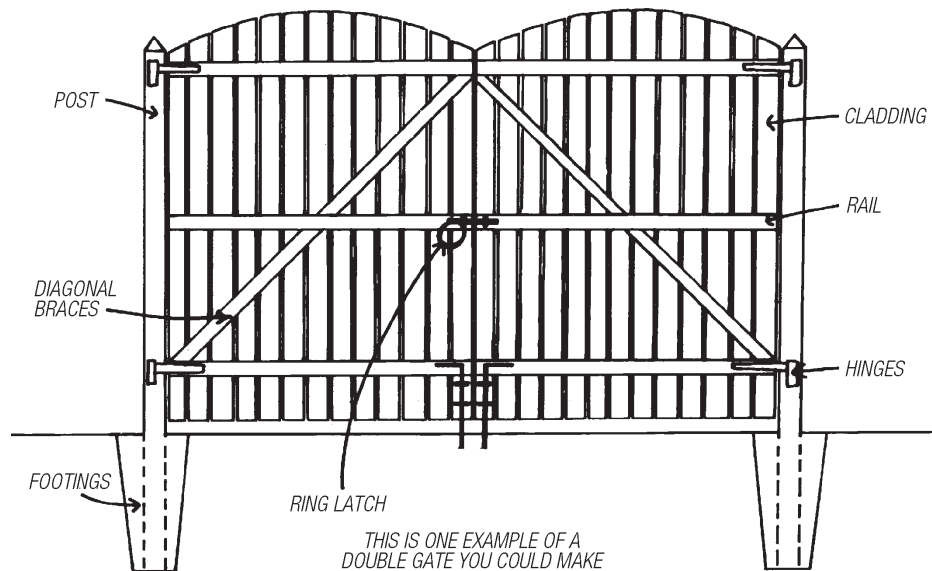

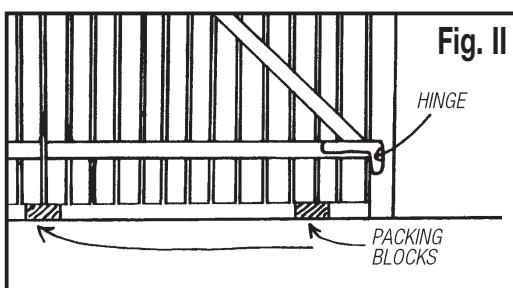
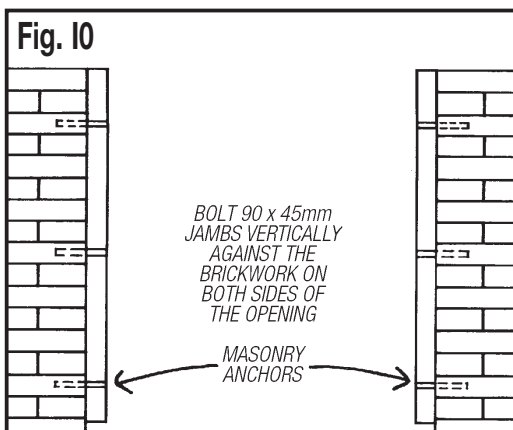
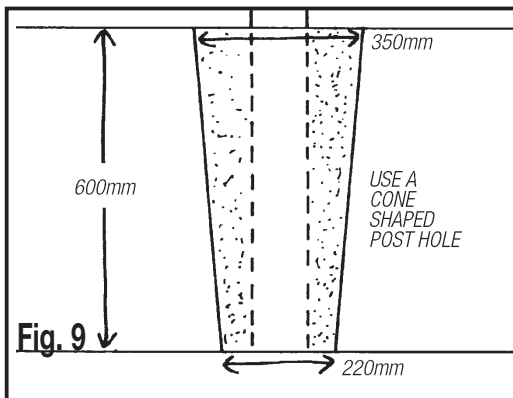
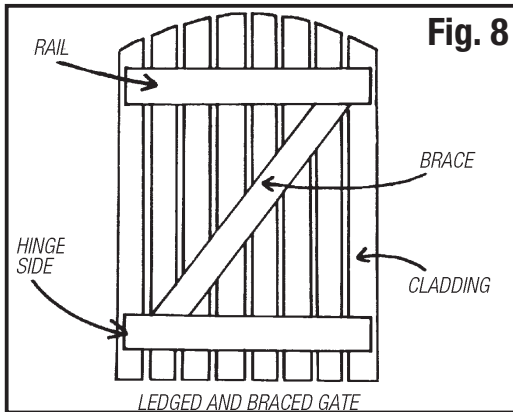
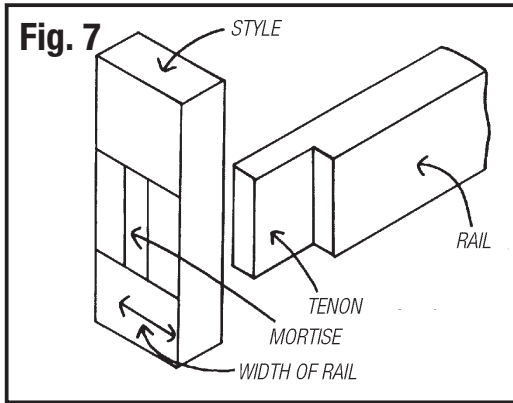

Lay the rails out on a flat surface, in the position they will be in when the gate is complete- ensuring that they are parallel to each other. Start fixing the lining board or pickets from one side across the top of the gate. Fix the lining with galvanised screws or nails, regularly checking that the rails are in their correct position and that the bottom of the lining is square to the side of the gate.

When complete, turn the gate over and mark out and cut a diagonal brace to fit between the rails (Fig. 8).

Finally, check that the diagonal lengths are equal in the same way as for mortise and tenon and fit the bracing with its lower end on the hinge side.

Step 4: Installing the gate

The stability of the post on which you will hang your gate is crucial – if it's insecure, then your gate will be as well.

Gate posts on timber fences should have a cone shaped gate post hole approximately 660mm deep x 350mm at the top and 220mm at the bottom (Fig. 9). You'll need to brace the post temporarily when setting it so it stays upright and straight. Then fill the hole with concrete mix. Check with a spirit level that the post is vertical and adjust the braces if necessary to hold it steady and square. Above ground, slope the concrete mixture away from the post to allow rain water to run off.

For brick fences, bolt 90 x 45mm jambs vertically against the brickwork on both sides of the opening using masonry anchors (Fig. 10). Be sure that the jambs are of hardwood or other durable timber. Position the masonry anchors 3 brick courses down from the top and 2 courses up from the bottom. A middle anchor may be needed depending on the height of your gate. Ensure that the hole is drilled into the brick and is deep enough to support the gate.

To install, first fit the hinges to the gate. Sit the gate in the opening on timber wedges or packing blocks to line everything up (Fig. 11). When all is correct and the gaps on each side (and in the middle for double gates) are even, drill one screw hole for each hinge and fit a screw. Then try out the gate, you may have to adjust the screws if it is not swinging freely. When all is well, fit the remaining screws.

Step 5: The finishing touch

Painting or staining your new gate is important for both looks and preservation of the timber. The choice of finish depends on you and the type of timber you used. For instance, if you chose treated pine, it doesn't normally require any added protection. But it will turn a silver grey colour if left to age naturally, so you could consider painting or staining it as well.

Finally, add your choice of hardware. Padbolts are an inexpensive method and can be padlocked for security. Ringlatches are available in a variety of styles. They add a decorative touch while holding gates shut but cannot be locked.

Now all that's left is to stand back, admire your handiwork and enjoy a grand entrance.

Tools for the job

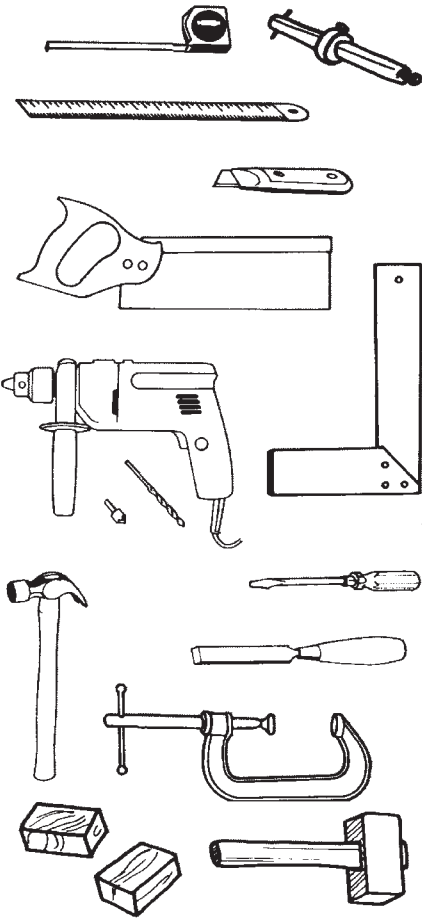

Measuring Tape or Ruler

Carpenter's Square

Marking Gauge

Tenon Saw

Power or Hand Drill and Bits

Wood Chisels

Wooden Mallet

Claw Hammer

Screwdriver and/or Cordless Drill/Driver

Utility Knife

Wedges or Timber Blocks
(made from scrap timber)

Clamps or Bench Vice

✓ Your Materials Checklist

Timber gates are exposed to harsh climatic extremes, so be sure all timber is of durable quality. We recommend Kiln-Dried Hardwood, or softwoods such as Treated Pine. The smaller sizes shown are suitable for gates using either the Mortise and Tenon or Ledge and Brace construction method (refer Step 3). However, if using the Ledge and Brace method for bigger gates across driveways, etc., specify the larger size. Gates higher than 1.2m will need a middle rail as well as top and bottom rails.

PRICE

	Laminated Sheet Standard Sizes	
	Kiln-Dried Hardwood 65 x 42mm or 90 x 32mm	
	Treated Pine 70 x 45mm or 90 x 35mm	
	19mm Dowel	
	Selected Cladding	
	Galvanised Nails or Screws	
	Gate Hinges	
	Padbolt or Ornamental Ringlatch	
	Optional	
	Masonry Anchors for attaching timber jambs to brick walls	
	Bag of Concrete Mix for setting gate posts	
	Other materials	

Verbal quotes are indicative only. Written quotes on materials are available upon request from your Mitre 10 store.



Visit www.mitre10.com.au for more **MITREPLANS**

10/10 handy hints to make the job easier.

■ When making a mortise and tenon joint, as with all joints, the most important step is to mark accurately – and double check all measurements and markings before cutting.

■ In making a mortise and tenon joint, use a sharp utility knife – it gives a thinner, more accurate line than even the sharpest pencil, and cuts the surface of the timber to help the saw leave a clean, sharp edge.

■ Weather protect your mortise and tenon joint, or when cladding is fastened to the frame, by staining or painting them first before assembling.

■ Use galvanised nails or screws in fixing cladding to the frame – ordinary nails will rust and stain the timber.

■ When measuring the gate's opening, remember to allow for clearance on both sides of the gate and the bottom.

MITREPLAN



Construct a timber gate

IMPORTANT: This project planner has been produced to provide basic information and our experienced staff are available to answer any questions you may have. However, this information is provided for use on the understanding that Mitre 10 is not liable for any loss or damage which is suffered or incurred (including but not limited to indirect or consequential loss), for any personal injury or damage to property suffered or sustained as a result of using the information contained in this MitrePlan Project Planner. Mitre 10 advises you to call in a qualified tradesperson, such as an electrician or plumber, where expert services are required, and to independently assess any safety precautions that will need to be followed prior to using the information in this MitrePlan Project Planner.

WARNING: There may be by laws or regulations of councils or other statutory bodies that you must comply with when following this MitrePlan Project Planner.



Your local MITRE 10 Store is:

MITRE 10