

# MITREPLAN

## Build your dog a kennel



## PROJECT PLANNER

An easy-to-follow guide to achieving a 10/10 result.

Outlines all the tools you will need for the job.

Including materials checklist.

**PLEASE NOTE:**

Before starting this project or buying any materials, it is well worth your time to read through all steps first to be sure you understand what is required.

**Mitre 10 is proudly  
Australian owned.**

**No. 33**

[www.mitre10.com.au](http://www.mitre10.com.au)

# MITRE 10

# Making a 10/10 kennel is doggone easy – with a little help from Mitre 10.

Everybody deserves a good solid roof over their head to keep out the elements. Especially your best friend. Even though he or she comes equipped with their own fur coat, sun, rain, wind and cold can make life pretty uncomfortable for them as well. So here's a haven for your hound which is easy to put together and can be adapted to suit all sizes of dogs. It's made of 12mm waterproof plywood cut to size and simply butt joined with glue, nails or screws, so construction isn't too complex. The roof is also hinged so it can be swung open for easy cleaning and airing. And it has an overhang at the front to help keep out the rain. So go to it. Pamper your pet with a happy home of its own. All you need are average handyperson skills, the right materials from Mitre 10, and this easy-to-follow guide.

## Step 1: Plan ahead

First, you have to decide how big your kennel needs to be. If it's too big, your pet won't feel secure in it. Too small and he or she will probably ignore all your efforts. It should be just big enough for your dog to stand up in and to turn around before lying down and curling up. Here's a rough guide to help you decide which size is best suited for your particular breed of dog:

- Small** for toy breeds and most small terriers.
- Medium** for Labradors, Irish Setters, Corgis, Cocker Spaniels, German Shepherds, etc.
- Large** for Afghans, Old English Sheepdogs, Great Danes, St. Bernards, Borzois, and so on. Or for smaller dogs sharing.

Once you've decided on the size, you can then determine the quantity of material you will need to buy. These are the dimensions for each of the three sizes:

**TABLE I: OVERALL DIMENSIONS (mm)**

Size:	Length	Width	Wall Height	Peak Height	Total Height
Small	600	480	440	240	680
Medium	1000	800	680	400	1080
Large	1500	1200	1080	600	1680

## Step 2: Start at the bottom

The floor should be at least 100mm off the ground to allow air circulation and to keep the kennel dry inside. So first build a subfloor frame from the 100 x 50mm treated pine. Treated pine is ideal for this because it is virtually rot proof.

After measuring up (using the dimensions in Table I for the kennel size you're building) and deducting ply wall thickness, pencil a line across the ends of the timber with a carpenter's square. Cut to length making sure the ends are square for a strong joint. Then lay the pieces out on a flat, firm surface and butt join each corner with 100 x 4.5mm galvanised nails or 75mm x 8 gauge wood screws (Fig. 1).

If nailing, drive nails at a slight angle for greater strength. If using screws, drill clearance holes in the top piece first. Place it against the end of the piece to be joined and drill pilot holes (slightly smaller than the size of the screw) into it. Apply construction grade adhesive following the directions on the cartridge, then screw together.

Next, measure and cut the centre subfloor frame cross piece and nail or screw it to the outside pieces. Do the same for the remaining two smaller cross pieces (Fig. 2). Then drill large holes through the subfloor frame to ensure cross-ventilation and allow water to run off.

Finally, measure and cut a piece of 12mm plywood and fix to the subfloor frame using adhesive and galvanised nails along all sides and cross pieces.

**Fig. 1**

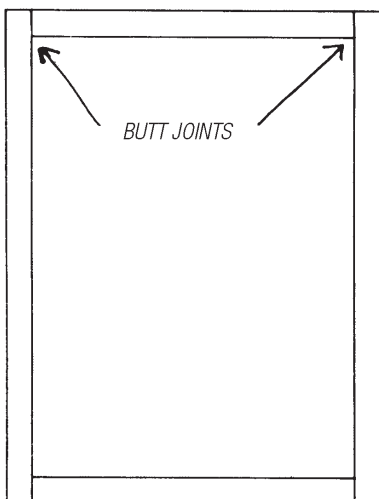

**Fig. 2**

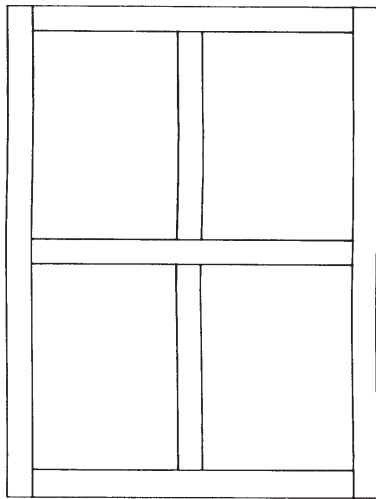

ADD CROSS PIECES TO BASE

**TABLE 2: DOOR OPENING DIMENSIONS**

Size:	Height mm	Width mm
Small	340	180
Medium	580	310
Large	980	400

### Step 3: Open the door

You must cut the door opening out of the front wall before you fix it to the floor. First, measure and cut the front wall 24mm wider than the floor width. This allows 12mm each side, the thickness of the plywood, for butt joints. Cut it to the wall height shown in Table 1 according to the size of the kennel you're building. Then measure 50mm from the top and bottom and rule lines across. Measure in from both sides as shown below to give the desired door opening as in Table 2, and pencil in the rounded top (Fig. 3).

Small 162mm

Medium 257mm

Large 412mm

The rear wall should also be cut 24mm wider than the width of the floor to allow for the side walls to be butt jointed to it.

The door opening can be cut with a jigsaw. Start by first drilling a hole in one corner at floor level (Fig. 3) and cut along the pattern and the floor edges.

### Step 4: Up the walls

Using construction grade adhesive and 40 x 2mm galvanised nails or 40mm x 6 gauge screws, fix the side walls to the subfloor frame. Screws should be placed every 200mm apart. Ensure that the subfloor frame and ventilation holes are visible below all wall panels.

Then fit the front and rear walls. Apply adhesive to the butt joints and floor frame, then glue and screw them to the frame as before. Finish off by nailing the end walls to the side walls at the joins.

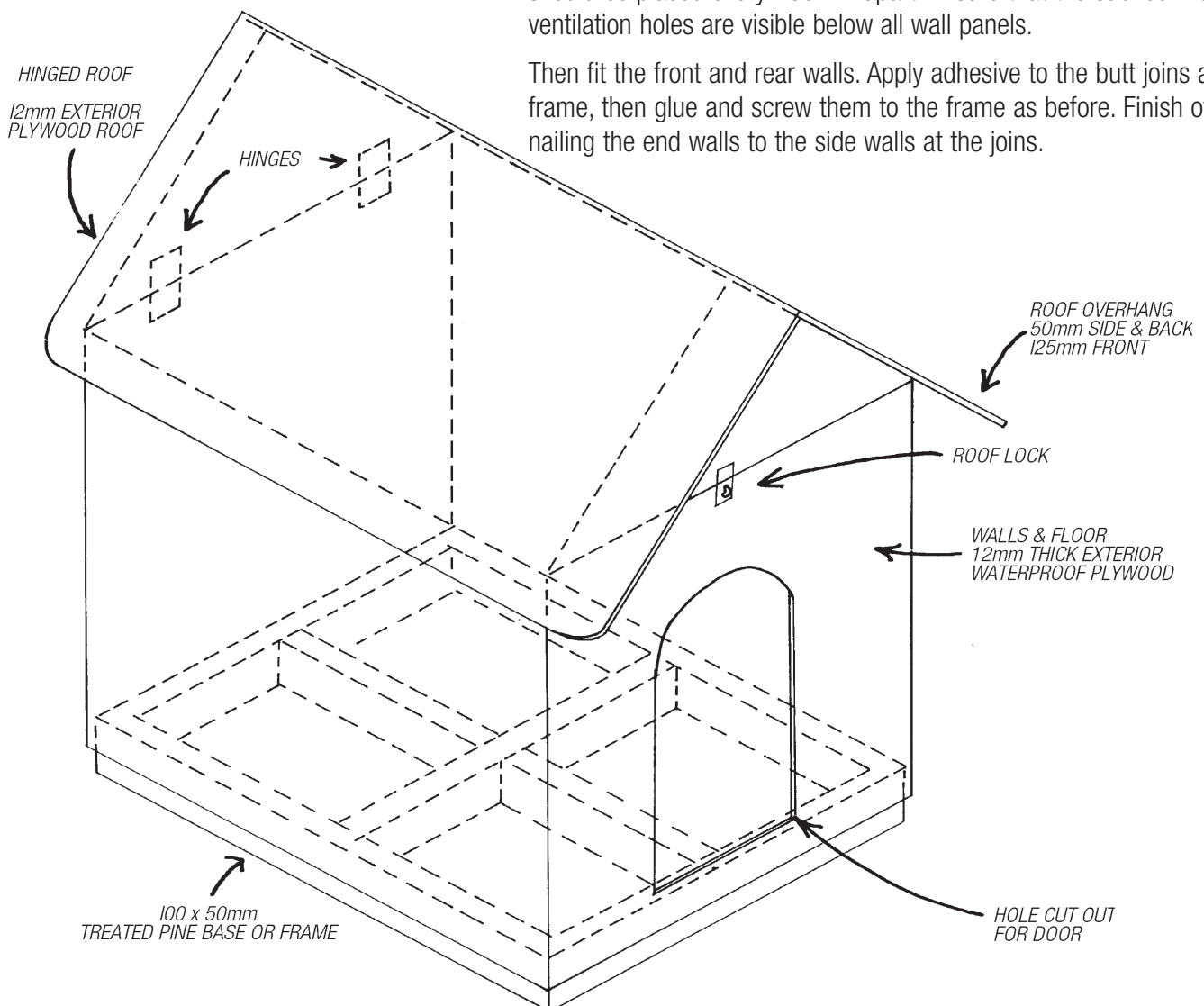

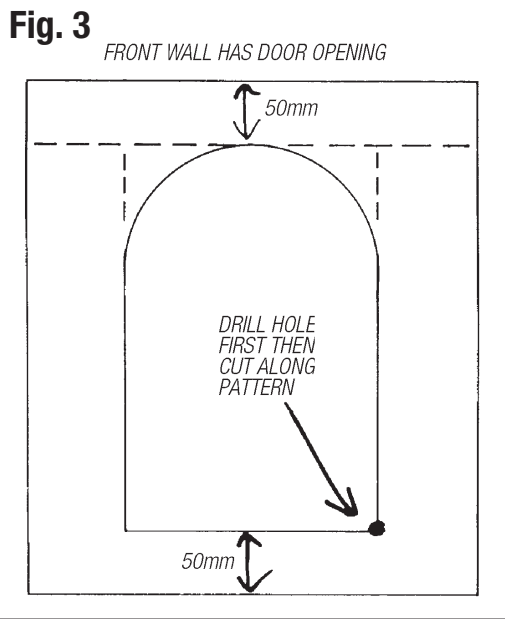

Finally, all inside and outside joins should be sealed with silicone to prevent draughts and stop fleas seeking shelter in them.

## Step 5: Roofing in

The roof is designed to be opened to allow for easy cleaning and airing. And corners are rounded to reduce the chances of injury.

The 'pitch' (or angle) of the roof is formed by a 45 degree triangular end at the front and rear. Make them by first measuring the width from the outside of the side walls across the top of the front and rear walls. Then, allowing for the peak height shown in Table I, cut a piece of plywood to size. From the inside, tack the triangular ends temporarily in position with scrap ply or timber and rest them on top of the front and rear walls.

You are now ready to cut the roof panels. Panel 'B' is cut 12mm wider than Panel 'A' to allow for the thickness of the plywood when the two pieces are butt joined at the peak of the triangular ends.

**TABLE 3: ROOF PANEL DIMENSIONS**

Size:	Length mm	Width mm Panel 'A'	Width mm Panel 'B'
Small	775	405	417
Medium	1175	635	647
Large	1675	915	927

The roof is fixed by placing Panel 'A' to line up with the apex (or point of the triangular ends), ensuring that there is a 125mm overhang at the front (Fig. 4).

Then apply adhesive to all edges that contact the panel and tack in position with small nails. Don't drive the nails all the way in – then you can remove them easily once the panel is screwed securely in place. Panel 'B' is then positioned to overlap the previous one at the apex (Fig. 4) and is fixed in the same way. When both panels are secured, apply silicone to the inside along the roof ridge for a neat finish.

Finally, fix hinges to the rear wall and a roof lock to the front wall (Fig. 5) with small galvanised bolts. Remove the scrap ply or timber pieces temporarily holding the roof to the walls and raise the roof on its hinges. Seal all joins inside the roof with silicone to keep out fleas and rain.

## Step 6: Finishing touches

Your completed kennel should be finished with an exterior gloss or semi-gloss to protect it and provide longer life. But don't paint the interior. And choose a light colour to help keep it cool inside. Don't neglect the underside of the floor either, to help prevent dampness from seeping up into the kennel. It's also a good idea to allow several days for the paint to thoroughly dry and for odours to evaporate before introducing your best friend to their new home.

If you like, the roof can be covered with light coloured metal Colourbond roofing. This is fixed to the plywood panels with adhesive and small 12mm clouts or self-tapping screws. Consider also insulating the inside of the roof to reduce noise from rain or hail – insulation is available from Mitre 10.

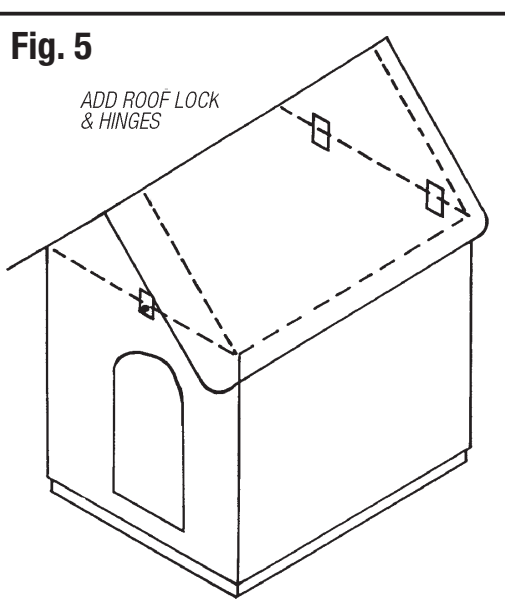
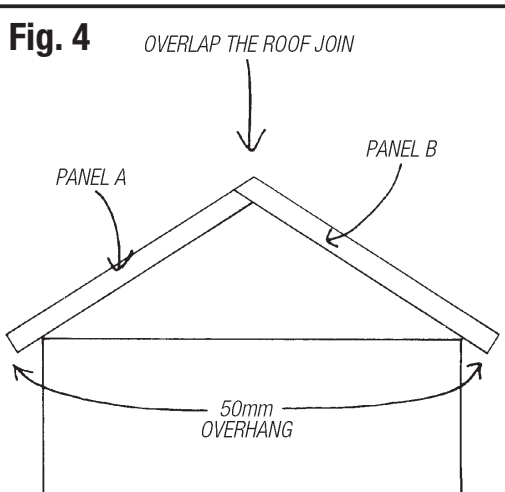



## 10/10 handy hints to make the job easier.

■ Measuring is easy, materials are expensive. Double check all measurements and markings before you cut any piece of timber.

■ To be both strong and neat, the ends of butt joints must be cut perfectly square – use a carpenter's square to mark across all four sides of the timber.

■ Smooth cut ends without rounding off corners by using a sanding block and rubbing across the cut end.

■ Use a sharp utility knife for marking out – it gives a thinner, more accurate line than even the sharpest pencil, and it cuts the surface of the timber to help the saw leave a clean, sharp edge.

■ When cutting several pieces of timber to exactly the same length, you will get more accurate results by clamping them together and measuring them as one. That way, even if you're a fraction out, the pieces will still all be identical.

■ To weather protect any timber that butts up against other sections of timber, paint it first before fixing together.

■ When using any power tool, protect your eyes by wearing suitable goggles.

# MITREPLAN



## Build your dog a kennel

**IMPORTANT:** This project planner has been produced to provide basic information and our experienced staff are available to answer any questions you may have. However, this information is provided for use on the understanding that Mitre 10 is not liable for any loss or damage which is suffered or incurred (including but not limited to indirect or consequential loss), for any personal injury or damage to property suffered or sustained as a result of using the information contained in this MitrePlan Project Planner. Mitre 10 advises you to call in a qualified tradesperson, such as an electrician or plumber, where expert services are required, and to independently assess any safety precautions that will need to be followed prior to using the information in this MitrePlan Project Planner.

**WARNING:** There may be by laws or regulations of councils or other statutory bodies that you must comply with when following this MitrePlan Project Planner.



**Your local MITRE 10 Store is:**

# MITRE 10