

MITREPLAN

Build a gazebo

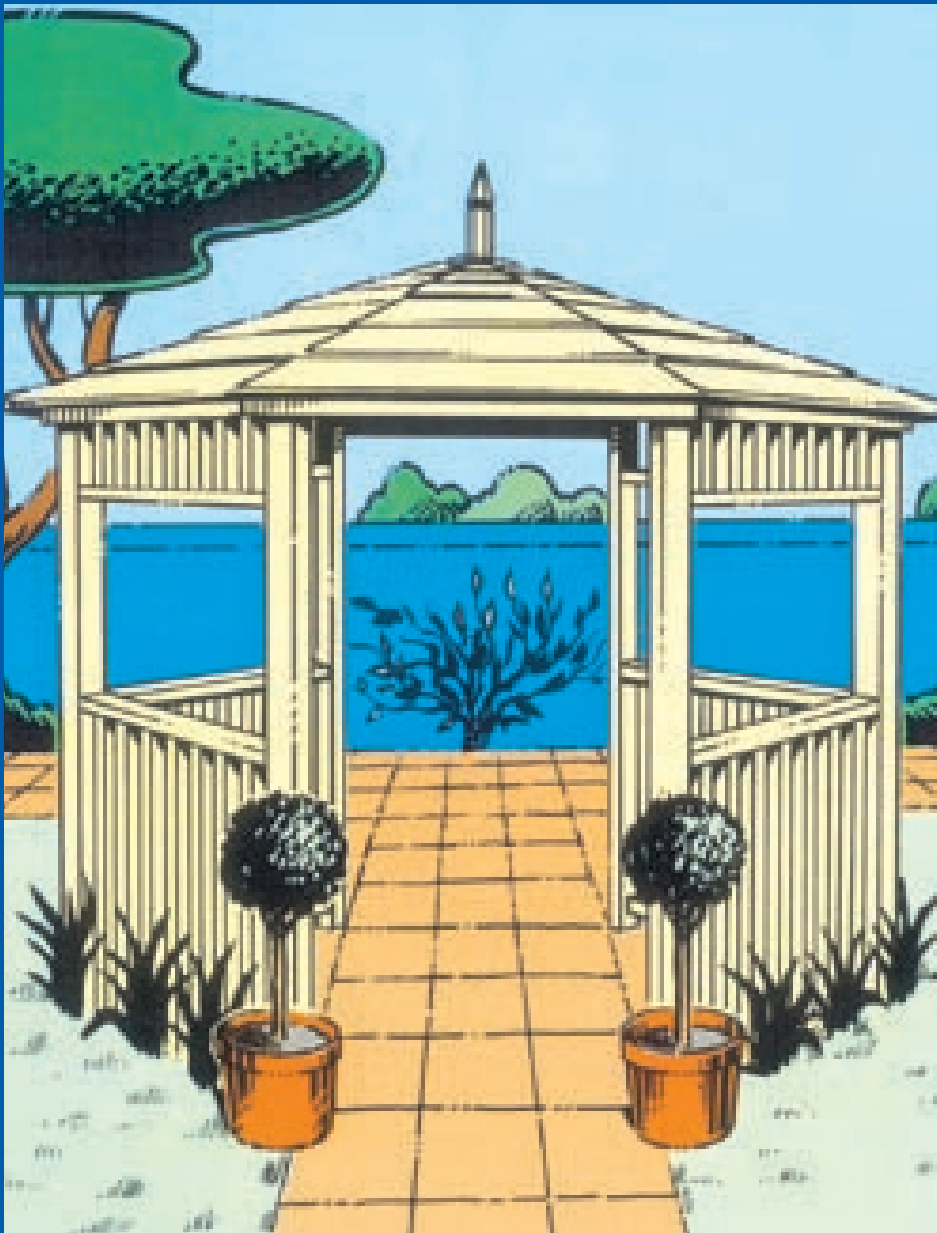

PROJECT PLANNER

An easy-to-follow guide to achieving a 10/10 result.

Outlines all the tools you will need for the job.

Including materials checklist.

PLEASE NOTE:

Before starting this project or buying any materials, it is well worth your time to read through all steps first to be sure you understand what is required.

Mitre 10 is proudly Australian owned.

No. 39

www.mitre10.com.au

MITRE 10 *All the help you need*

Build a shady retreat for a 10/10 summer - with a little help from Mitre 10.

Looking for a shady, airy place to escape the sun and summer heat? Then consider building this elegant, six-sided gazebo – ideal for relaxing or entertaining.

It covers an area of about six square metres (anything over this may require a building permit – check with your council before buying any materials). And you can further enhance the basic design by adding a handrail on four sides or a timber frieze under the beams.

Flooring can range from basic rammed earth to concrete, fine gravel, timber decking, pavers, slate, even wood chips – it's up to you.

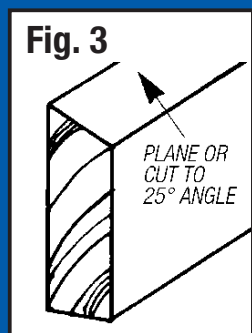
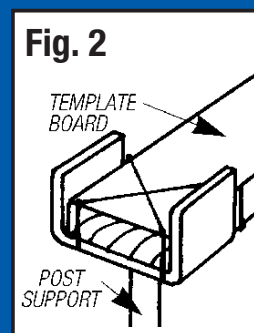
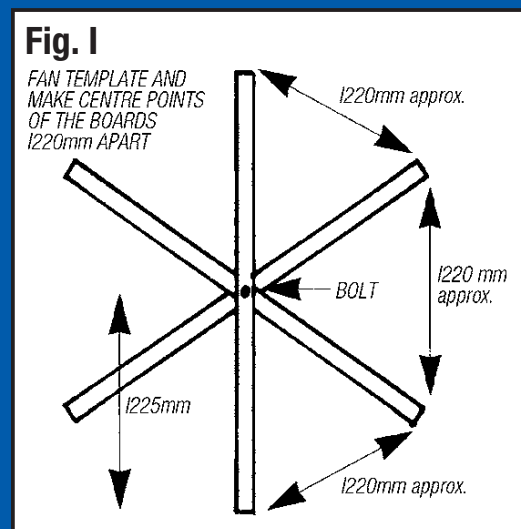

Step 1: Getting started

First, clear and level the site. If you're excavating into a slope, make sure there's a slight fall to the low side so rainwater can run off. Then make a template to accurately locate the base of the gazebo. Cut three 90 x 19mm boards to 2450mm long – making sure they're straight. Clamp them together and mark the precise centre in both length and width. Drill a 6mm hole through the centre and loosely fix the three boards together with the 75 x 6mm bolt and nut. Finally, measure and mark the centre of each board at each end.

Step 2: Locate the base

Fan out the template on your site so that the centre points are the same distance apart, approx. 1220mm (Fig. 1). Tighten the nut to rigidly fix their positions. Mark the end of each board on the ground – this represents the outside face of the posts and where the post supports are to be set.

Step 3: Set post supports

Dig 300 x 300 x 450mm deep post holes. Then tie post supports to the end of each template board with wire or string (Fig. 2), making sure the outer edge of each support is flush with the end of the board. Lay out the template with the supports in their holes. If necessary, build up the template at various points with scrap timber to ensure it is level all around the perimeter. Fill the holes completely with concrete, adjusting post support locations if necessary when the last hole is filled. Leave to set for a week.

Step 4: Cut the beams

First, cut the top surface off all 120 x 45mm perimeter beams (Fig. 3) to a 25 degree angle using a power saw fitted with a fence, or a power planer. Then on one beam, draw a line across the face at one end with a square. Set your saw to 30 degrees and cut this off. Place the beam on the template, aligning the cut end with the centre mark on the end of the template arm and with the inside edge of the beam touching the corner of the arm (Fig. 4). At the other end of the beam, mark its outside face where it meets the centre line of the opposite template arm (Fig. 5). Cut square across at this mark at the 30 degree angle. Do the same for the remaining beams, working around all template arms. All beams should be the same length but it's more important that they match the actual length of their respective post support locations.

Step 5: Prepare the posts

First, check each post support is at the same level, adjusting their lengths if they're not. Then cut the 90 x 90mm posts to 2350mm long and cut out the housing for the beams. Mark the top of the posts for the cuts needed (Fig. 7). Set your circular saw to 30 degrees and carefully cut down both sides until the blade reaches the 120mm mark. Finish the cuts with a handsaw, as the depth of cut with a circular saw will not finish parallel to the surface. Then remove the waste by cutting square across the face with the handsaw.

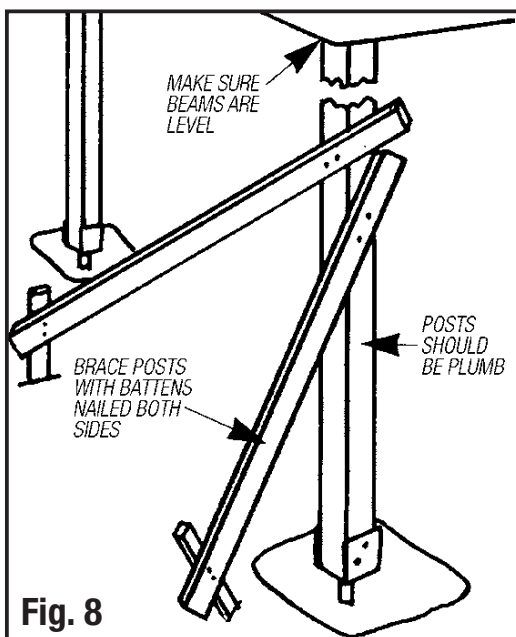
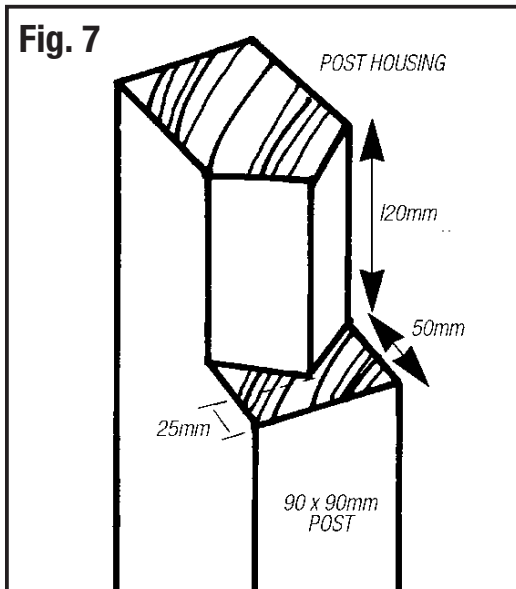
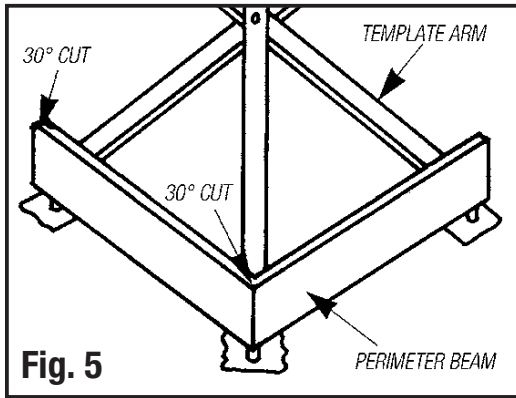
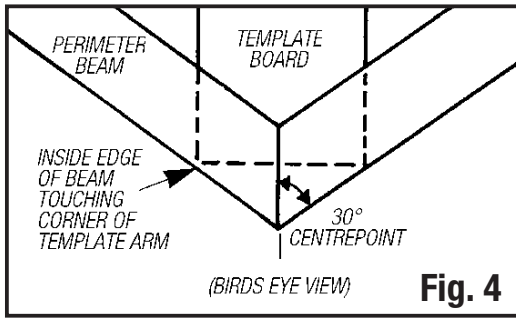

Step 6: Fix beams to posts

Lay two posts flat with the housings facing upwards. Then lay the corresponding beam in the post housings, with the posts and beam square to each other, and clamp in position. Drill a 10mm hole, 45mm from the top of the housing, through the beam and post at each end. Then fix with I25 x 10mm coach bolts, nuts and washers. Repeat with the other four posts and their corresponding beams. Then, with a person at each end, stand a completed frame in the correct post supports. Check that the posts are plumb in all directions and that the beams are level and in a common line. Then brace with battens nailed to two sides (Fig. 8). Prop up the second post and beam frame in the same way and drill and bolt on the beam between these two frames (placing the bolt 45mm up from the bottom of the beam). Next, erect the remaining frame and beams as before. It is now likely that the posts will not be plumb, so re-prop as necessary until they are all plumb in all directions. Now drill through the post supports into the base of the posts, place the I25mm coach bolts and nuts, and tighten.

Remember to firmly brace the structure while working on the roof frame. The outer edge of the beams should all be of equal length where they join posts.

Step 7: Raise the roof

Begin by shaping a central apex block to create a square fixing point for

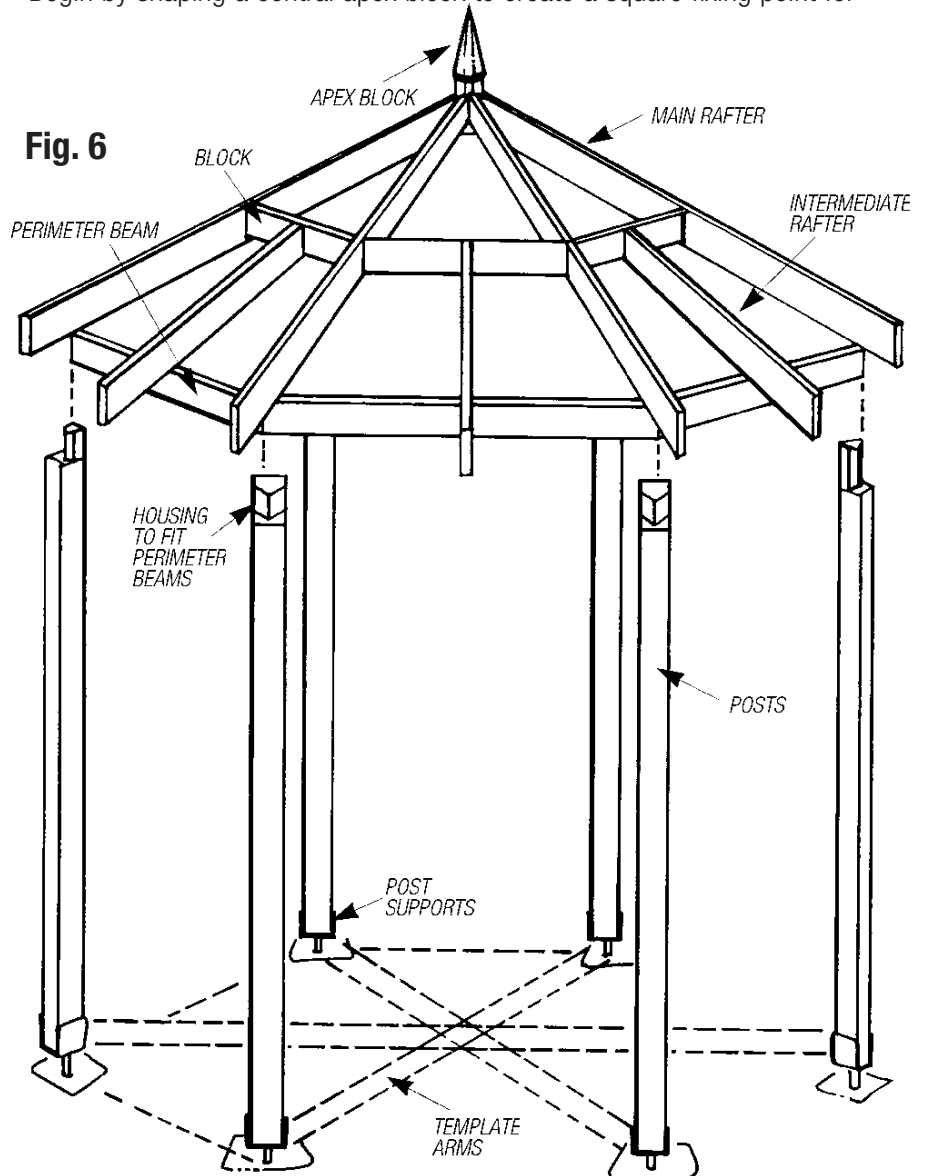

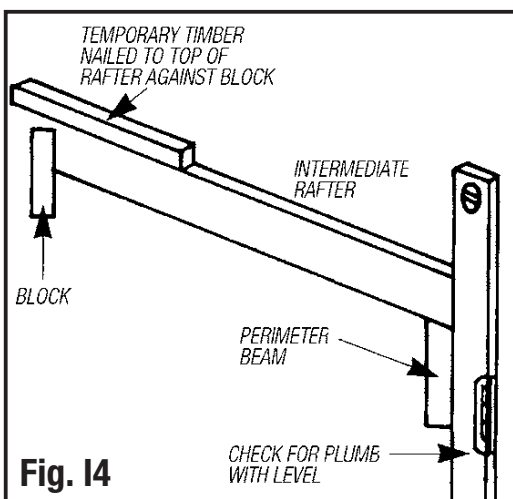
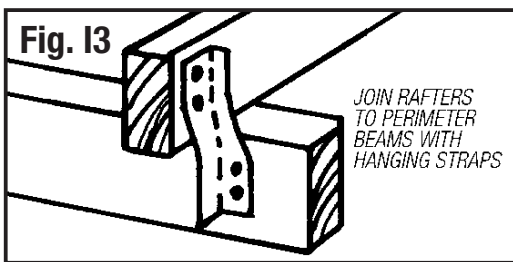
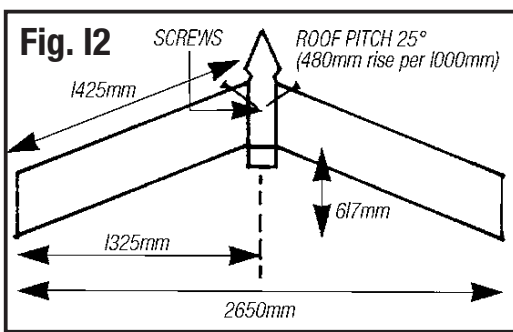
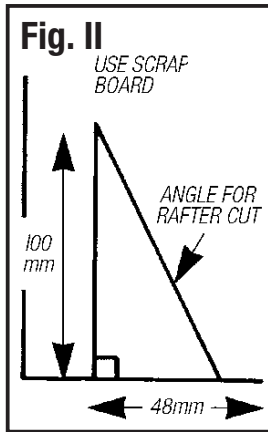
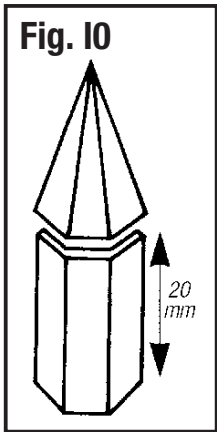
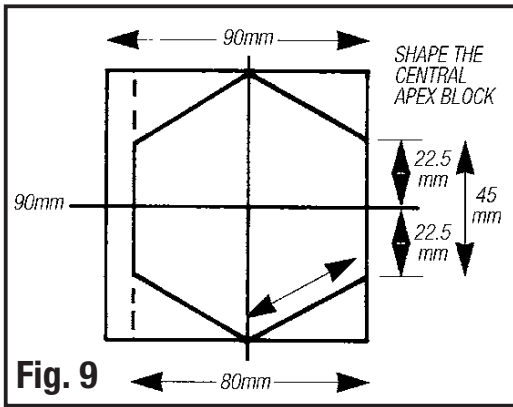

each rafter. Cut the 90 x 90mm block to 550mm long. Saw or plane off 10mm from one side so it now measures 90 x 80mm. Mark and cut one end as shown (Fig. 9). With a little extra work, the top can also double as a finial (Fig. 10). The next job is to cut 6 main rafters to 1475mm long which includes an overhang of about 100mm beyond the front surface of the perimeter beams. Then cut the ends of each rafter at an angle to give the pitch of the roof. First, mark out the correct angle on a scrap piece of board (Fig. 11), then set your sliding bevel to the angle and transfer to both ends of each rafter (Fig. 12).

After cutting, fix one pair of opposing rafters to the apex block with 100mm screws (Fig. 12). When assembled, raise the main frame up into position (you'll need extra hands here) and fasten each rafter to the perimeter beams by skew nailing with 75mm nails, and fixing joist straps using 30mm galvanised clouts. (Fig. 13). Now add the blocking between the rafters (Fig. 6). Mark down from the roof apex 500mm on both sides of each rafter. Set your saw to 30 degrees and cut 120 x 45mm blocks to fit between each pair of rafters. Fix by skew nailing into the main rafters, making sure they're kept straight. Finally, fit the intermediate rafters. Start by marking the centre on both the blocking and perimeter beam between each pair of rafters. Temporarily nail a scrap board to the top edge of the intermediate rafter at one end and hold against the blocking (Fig. 14). Place a spirit level against the perimeter beam and mark up plumb on the intermediate rafter. Adjusting your bevel to this mark, transfer this angle to the end of the rafter and cut off square. Finally, temporarily fix a straight piece of timber to the ends of two adjacent main rafters. Hold the angled end of the intermediate rafter against the block, mark its length where it meets the temporary bracing and square cut the angle. Fix by nailing to the blocking and skew nailing to the beam.

Step 8: Add the roofing

Cedar weatherboards are easy to install, require little maintenance and give a traditional, rustic appearance. Or, consider a clear polycarbonate product, lattice or shade battens to let the light in. Whichever you use, place your roofing in position. Then mark over the centre line of each main rafter with a straightedge before cutting. Finish with a capping of timber or pre-formed metal such as galvanised plasterer's angle.

Step 9: Finishing touches

Handrails: Leave two opposite sides open for easy access. Skew nail the top rail to the posts with 75mm galvanised nails 850mm above ground level and the bottom rail 740mm below this. Square dressed balusters are fixed with two 40mm galvanised nails top and bottom 50mm apart. Alternatively, diagonal bracing is fixed from corner to corner, one piece in front of the other. For trellis, use rebated nails. Fix the bottom rail first, fit the trellis into it, then fix the top rail over it.

Timber Frieze: Measure 150mm down from the beams at each post and cut 70 x 19mm frieze bases to fit. Mark 75mm apart for the 'droppers' on the underside of the beams and on the frieze bases. Cut 130mm long 'droppers' and skew nail to the beam with 40mm galvanised nails. Place the bases hard under the 'droppers', fix to the post, then to the 'droppers'.

Tools for the job



Pencil

Shovel

Spirit Level

Measuring Tape

Hand Saw

Hammer

Power Drill & Assorted Bits

Power Circular Saw

Power Planer

Carpenter's Square

Sliding Bevel

2 Quick-Release Clamps

Adjustable Wrenches

Screwdriver Set

Step Ladder

All the help you need

✓ Your Materials Checklist

Timber Sizes shown are for Treated Pine. Material quantities will depend on the size you make your Gazebo – our list is for one covering an area of approximately 6 square metres (about 65 sq. ft) x approximately 2.13m high under the beams.

PRICE

3 – 90 x 19 x 2700mm template	
6 – 90 x 90 x 2400mm posts	
3 – 120 x 45 x 3000mm perimeter beams (cut 6)	
6 – 120 x 45 x 1500mm rafters	
3 – 120 x 45 x 2100mm rafters (cut 6)	
3 – 120 x 45 x 1500mm blocking (cut 6)	
1 – 90 x 90 x 600mm apex block/finial	
27 – 180 x 2700mm cedar weatherboards or alternative roofing	
6 – 1500mm galvanised plasterer's angle for roof	
Lengths of 50 x 25mm ordinary builders (OB) hardwood bracing battens	
Optional	
3 – 70 x 19 x 2700mm frieze base	
3 – 42 x 19 x 2400mm frieze droppers (cut 54)	
4 – 70 x 35 x 2700mm hand & bottom rails	
9 – 70 x 19 x 3000mm balusters (cut 36 x 740mm)	
1 – 3000mm length contemporary post corners moulding	
Hardware	
6 – post supports	
24 – 125 x 10mm coach bolts, nuts & washers	
1 – 75 x 6mm bolt & nut	
Pkt. 75mm and Pkt. 40mm galvanised bullet head nails	
Pkt. 100mm zinc wood screws	
Pkt. 75mm zinc wood screws	
12 joist straps	
Pkt. 30mm galvanised clouts	
2m ² pre-mixed concrete	
Thin tie-wire or string	
Selected paint or timber stain	

Verbal quotes are indicative only. Written quotes on materials are available upon request from your Mitre 10 store.

Visit www.mitre10.com.au for more **MITREPLANS**

10/10 handy hints to make the job easier.

- Save time and effort by hiring or buying an auger-type post hole digger.
- Post holes should be measured centre to centre to make sure they are an equal distance apart.
- Be sure to use galvanised fixings – ordinary nails, coach bolts and screws will rust and stain the timber.
- Finishing will be easier if you paint or stain all materials first before building – then, when the job is done, simply touch-up marked areas, joints, etc.
- **Remember, a building permit may be required. Check with your council first about local regulations.**



MITREPLAN

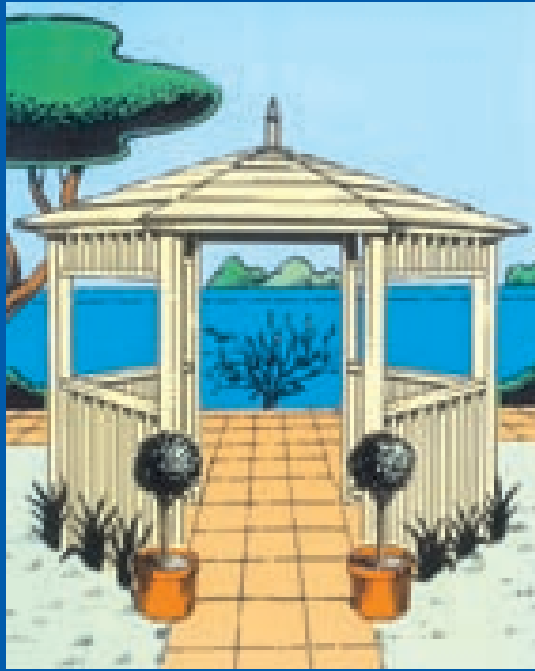

Build a gazebo

IMPORTANT: This project planner has been produced to provide basic information and our experienced staff are available to answer any questions you may have. However, this information is provided for use on the understanding that Mitre 10 is not liable for any claim, cost, expense, loss or damage which is suffered or incurred (including but not limited to indirect or consequential loss), for any personal injury or damage to property suffered or sustained as a result of or arising out of or in any way connected with using the information contained in this MitrePlan Project Planner. Mitre 10 advises you to call in a qualified tradesperson, such as an electrician or plumber, where expert services are required, and to independently assess any safety precautions that will need to be followed prior to using the information in this MitrePlan Project Planner.

WARNING: There may be by laws or regulations of councils or other statutory bodies that you must comply with when following this MitrePlan Project Planner.



Your local MITRE 10 Store is:

MITRE 10
All the help you need