

# MITREPLAN PROJECT PLANNER

## Renovate your bathroom



- **An easy-to-follow guide to achieving a perfect result.**
- **Outlines all the tools you will need for the job.**
- **Includes a materials checklist.**

#### **PLEASE NOTE:**

Before starting this project or buying any materials, it is worth your time to read all steps thoroughly first to be sure you understand what is required.

**Mitre 10 is proudly Australian owned.**

# #37

**mitre10.com.au**

# MIGHTY HELPFUL™ MITRE 10

## MIGHTY TOOLS FOR YOUR MITREPLAN



Hand saw  
 Electric drill and bits set  
 Tungsten-tipped 'score and snap' knife  
 Hand guillotine  
 Claw hammer  
 Rasp file  
 Trowel or broad knife  
 Electric planer  
 Sanding float  
 Hole saws (optional)  
 Jigsaw and tungsten-tipped blade (optional)

## MIGHTY HELPFUL CHECKLIST

	ORDER
Villaboard fibre cement sheets	
30 x 2.8mm	
Galvanised fibre cement nails	
"Wet Area" flashing	
Continuous galvanised metal angle (for internal corners)	
Perforated metal angle (for external corners)	
Joint bedding cement	
Topping compound	
120 grit sandpaper	
Perforated paper reinforcing jointing tape	
Flexible silicone sealant	

Verbal quotes are indicative only. Written quotes on materials are available upon request from your Mitre 10 store.

### Step 6: Finishing touches

Tiling can now be carried out. Two MitrePlans #15 Take on wall tiling and #8 Tile your own floors, are available to make a simple job for the handyperson. Both take you through every stage of doing it and achieving professional results. When tiling over a timber floor, sheet first with Hardie's Ceramic Tile Underlay. And use proper floor tiles to match your wall tiles – wall tiles are not strong enough to take the stress and pressure of floor use.

When the floor is finished, the plumber can be recalled to install the toilet and cistern and connect it to the water supply. And the electrician to install new light fittings, switches and any exhaust fan.

Finally, seal all gaps around the vanity unit and bath with a flexible silicone sealant to ensure water cannot leak behind them. Then add any window treatment, accessories and towels and your new bathroom is complete.

## Pull the plug on your old bathroom - with a little help from Mitre 10.

It has been recorded that Queen Elizabeth I bathed once a month whether she required it or not.

But today, with the daily shower part of the Australian lifestyle, the bathroom is one of the most used areas in a home. It can also be one of the most glamorous, with a wealth of fittings, fixtures and accessories available.

Naturally, when renovating such "wet areas" (including kitchens and laundries), you must ensure walls, ceilings, and floors are waterproof. This is where Hardies fibre cement building products are ideal on existing wall framing, ceilings and floors. They are immune to permanent water damage and won't rot.

And using the basic steps in this MitrePlan, you can do it. Apart from plumbing and electrical work which must be done only by qualified tradespeople, the rest of the job is within the scope of the average handyperson and can save you thousands of dollars.

### Step 1: Plan ahead

Well designed and decorated, an updated bathroom can increase the value of a home by more than the actual cost of the work. So consider carefully what needs to be done.

Perhaps re-tiling walls and floors is all you need. Or replacing the old vanity, basin and toilet. In this case, take samples of tiles, wallpaper or paint with you when shopping for fixtures so you can directly compare colours before you start.

If your bathroom looks small, re-doing it in pale colours can make the room appear larger. Or add mirrors to give the feeling of spaciousness.

But maybe actual size is the problem and nothing but a complete renovation will do. If it's too small, consider re-designing the existing space to make it more workable (Fig. 1 and 2).

Or, if it's large enough, how about adding a double shower or a spa, or his and her basins in the vanity unit.

Bathrooms in older homes often had a linen cupboard. This could be removed and a shower cubicle included, or a larger vanity, or simply for more floor space (Fig 3).

If it also includes a toilet, you could make it more private by partitioning it off with a 1.8 – 2.0m high wall, leaving the top open or glazing it in (Fig. 4).

Whatever your plans, the correct wall lining is important to prevent moisture from penetrating into structural timbers. Hardie's Villaboard is ideal, especially for tiled bathrooms. Or, save yourself this task and choose Hardiglaz Swirl which has the feel and glossy look of ceramics. It does the same job as Villaboard but needs no further finishing.

Fig. 3 - Old bathroom with linen cupboard

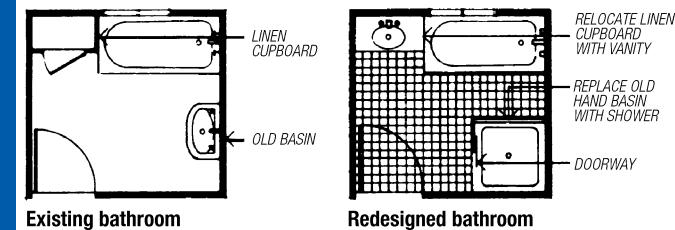
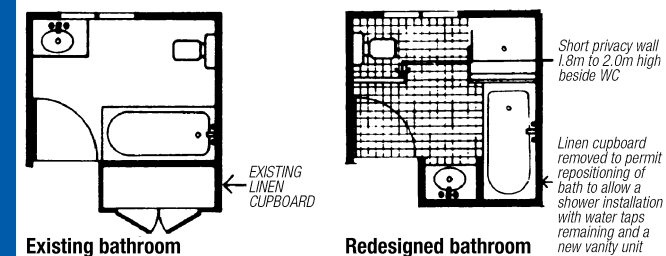
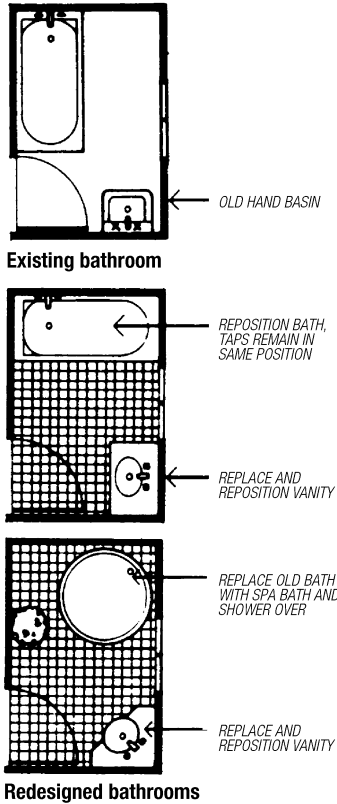

Fig. 4 - Bathroom with toilet



**Fig. 1 -  
The narrow bathroom**



**Fig. 2 -  
The tiny square bathroom**

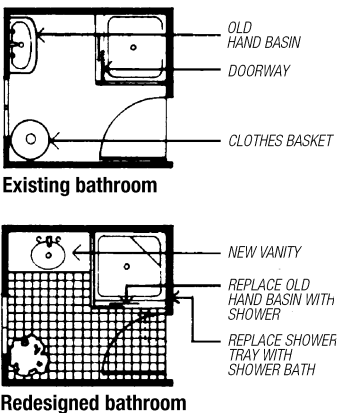

**Step 2: Demolition**

If it's a full bathroom renovation, start by turning off the water supply at the mains and electricity at the main switchboard. Then remove all existing fittings. If possible, plan to leave plumbing in place to save money. Remove architraves, skirting and cornice next, and finally, old wall lining. Using a long straight edge as a guide, check that studs and noggings are aligned straight to ensure your new wall linings are fixed flush and true. Remove high spots with an electric plane and pack out low spots with thin pieces of scrap timber or hardwood fixed in position with nails or glue. Ensure all noggings are fixed in a straight line behind the horizontal joint in the new Villaboard wall lining.

**Step 3: Add flashing**

Where water damage could occur at junctions, especially bath or shower areas, all corners should be fixed with Hardie's wet area flashing following the manufacturer's instructions. In shower recesses, it should extend into the shower tray. Where tiles are to be used, corners should be covered first with continuous metal angles (Fig. 5). At this stage, any new plumbing and electrical work are also done.

**Step 4: Line the walls**

Before fixing your Villaboard, check that all electrical wiring and plumbing is set back in the wall cavity to avoid damage by nails. Fix the sheets horizontally for flush joints. Ends of sheets should not coincide with the corners of windows and doors.

**Cutting.** There are three suitable methods: Using a special tungsten-tipped "score and snap" knife, score from the face side of the sheet against a straight edge, repeating the action to a depth of about 1/3 sheet thickness. Then snap upwards to break and clean edges with a rasp if needed (Fig. 6). Or, using a hand guillotine, cut on the off-cut side to allow for the thickness of the blade (Fig. 7). Hand sawing is also suitable for general cutting and notching. For notches, make saw cuts, then score along the back with the "score and snap" knife, and snap upwards (Fig. 8).

Holes for shower and bath taps and other fittings are easily cut. For small rectangular or circular holes, drill a series of holes around the perimeter of the hole, then carefully tap out the waste with a hammer (Fig. 9). For large openings, such as for wall ventilation, score deeply around the opening, drill a hole in the centre, then saw from the centre to the corners (Fig. 10). Finally, tap out the waste pieces from the face side, then round the corners with a rasp to eliminate stress points. Alternatively, hole saws or a jig saw with a tungsten-tipped blade can be used.

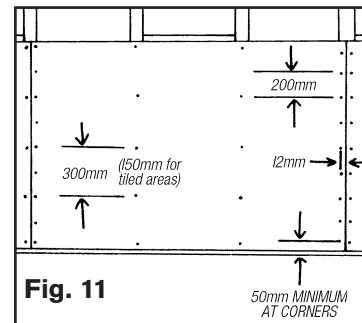
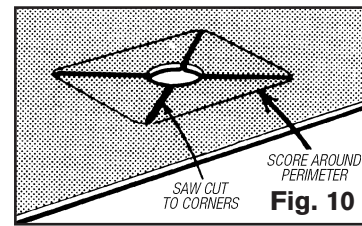
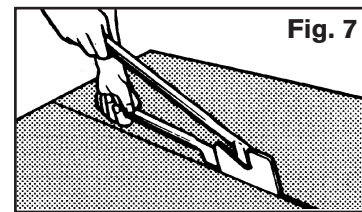
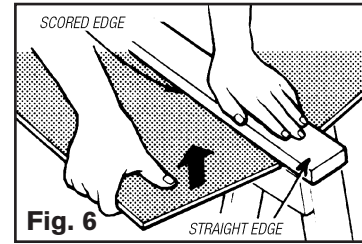
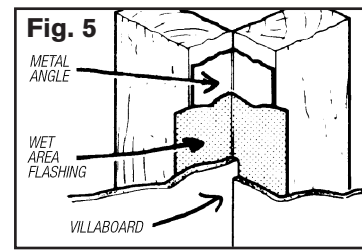
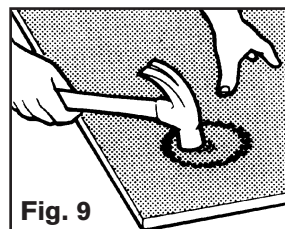
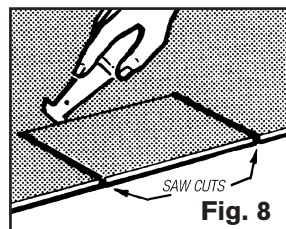

**Fixing.** Sheets should be fixed horizontally and nailed not less than 12mm from the edges and 50mm from corners (Fig. 11). Drive nails just below the surface without punching in. They should be fixed at 200mm centres on each stud along the edges.

Along intermediate studs, nail at 300mm centres for united areas, or 150mm centres if you're tiling over it (Fig.11). Where wall/floor junctions are flashed, such as in shower recesses, sheets must not be fixed to bottom plates as the nails would penetrate the flashing. Where shower bases are used, install noggings 25mm above the top of the flashing of shower base and fix sheets to these (Fig. 12).

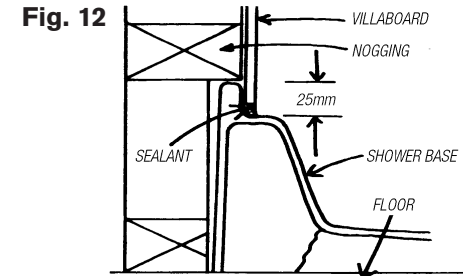

**Step 5: Jointing**

Sheet joints are covered with special perforated paper reinforcing jointing tape set in a bedding cement (Fig. 13). First, mix the bedding cement according to the manufacturer's directions. Then apply firmly into joints using a trowel or broad knife. Only do about 5m at a time to avoid cement drying out. Thoroughly embed the jointing tape, flattening with a trowel or broad knife (Fig 14) and allow to dry. Apply cement to nail heads as well. When dry, apply a second coat to joints and a second coat to nail heads. For internal corners, use a broad knife to fill the joint with bedding cement, crease jointing tape with fingers and work into the joint by applying another coat of cement. For external corners, trowel on cement and allow to dry before applying a second coat. When thoroughly dry, apply a topping compound. Allow to dry and sand to smooth, flush finish with 120 grit sandpaper. If walls are to be tiled, DO NOT use topping compound.

Cornices can now be installed to wall/ceiling junctions, and architraves around windows and doors. And the plumber called to install bath, basins and tap fittings.

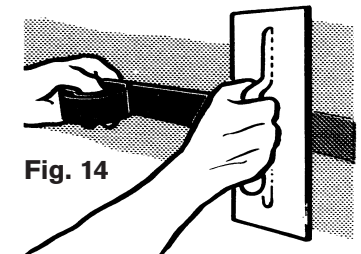
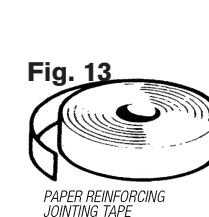

# Renovate your bathroom

## MIGHTY HELPFUL HINTS TO MAKE THE JOB EASIER

- If fully renovating your bathroom, provide a thick protective covering over any retained fittings to avoid damage.
- To save money, leave plumbing in place if possible – just buy new taps and outlets and fit into existing pipes.
- If the job is to take some time, ask the plumber to seal off outlets in the bathroom while work is progressing but allowing water to the rest of the house.
- Ensure Villaboard sheets are completely dry before fixing. And stack on edge or lay flat on a smooth, level surface to prevent chipping of corners.
- When forming holes, ensure that the sheet edges are properly supported to avoid damage.
- The cut edges of Villaboard sheets do not need to be sealed – they are completely immune to permanent water damage.
- Thoroughly clean all surface dust from lining sheets with a damp cloth before applying tile adhesive to ensure maximum bond.

**Mitre 10 gratefully acknowledges the assistance of James Hardie & Co Pty Ltd in the preparation of this MitrePlan.**



**IMPORTANT:** This project planner has been produced to provide basic information and our experienced staff are available to answer any questions you may have. However, this information is provided for use on the understanding that Mitre 10 is not liable for any loss or damage which is suffered or incurred (including but not limited to indirect or consequential loss), for any personal injury or damage to property suffered or sustained as a result of using the information contained in this MitrePlan Project Planner. Mitre 10 advises you to call in a qualified tradesperson, such as an electrician or plumber, where expert services are required, and to independently assess any safety precautions that will need to be followed prior to using the information in this MitrePlan Project Planner.

**WARNING:** There may be by laws or regulations of councils or other statutory bodies that you must comply with when following this MitrePlan Project Planner.

**Your local MITRE 10 Store is:**